

Low-Pressure filter

Pi 150

Operating pressure 10 (25) bar, Nominal size up to 630

1. Features

Efficient filters for modern hydraulic systems

- Modular design
 - Minimal pressure loss
 - Compact design
 - Visual / electrical / electronic differential pressure indication
 - Threaded or SAE 4 bolt flange ports
-

Quality filters, easy to service

- Highly efficient Mic- or Sm-x-filter elements
 - β -rated elements per ISO 4572
 - Large dirt holding capacity and high differential pressure stability providing optimal element service life
 - 100% bubble-point tested elements
-

World-wide sales

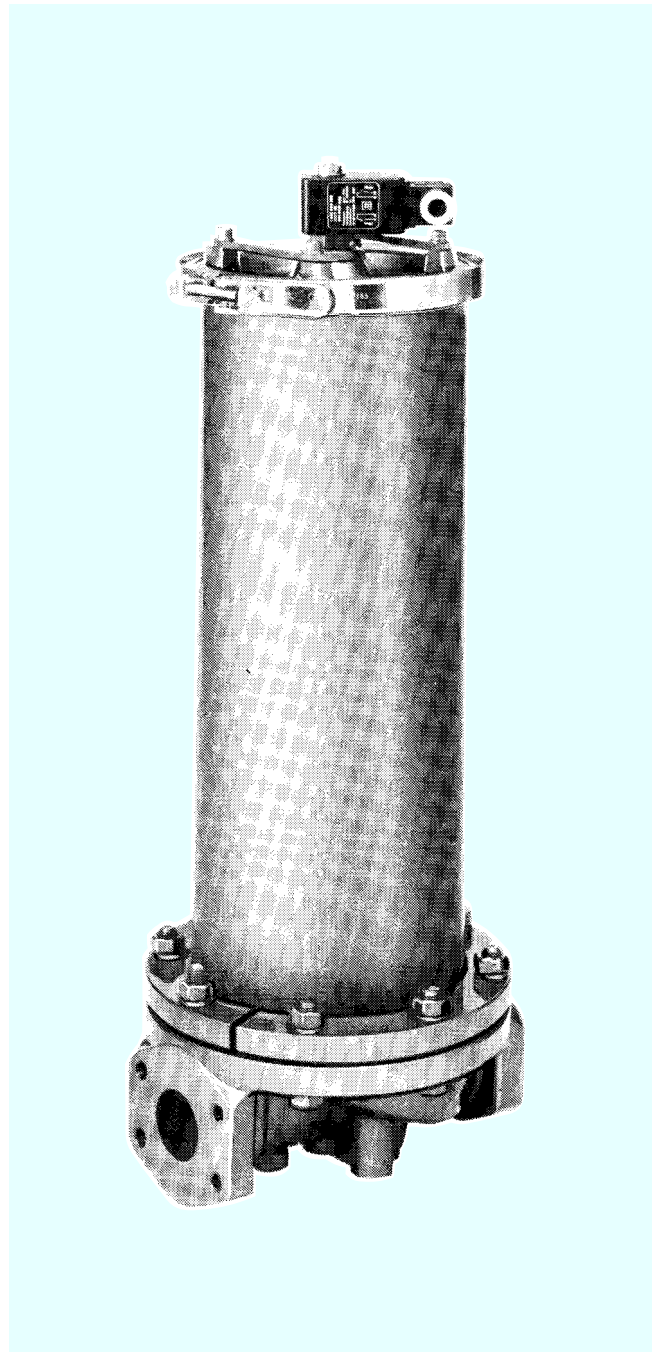

2. Flow rate / pressure drop curve compl. filter

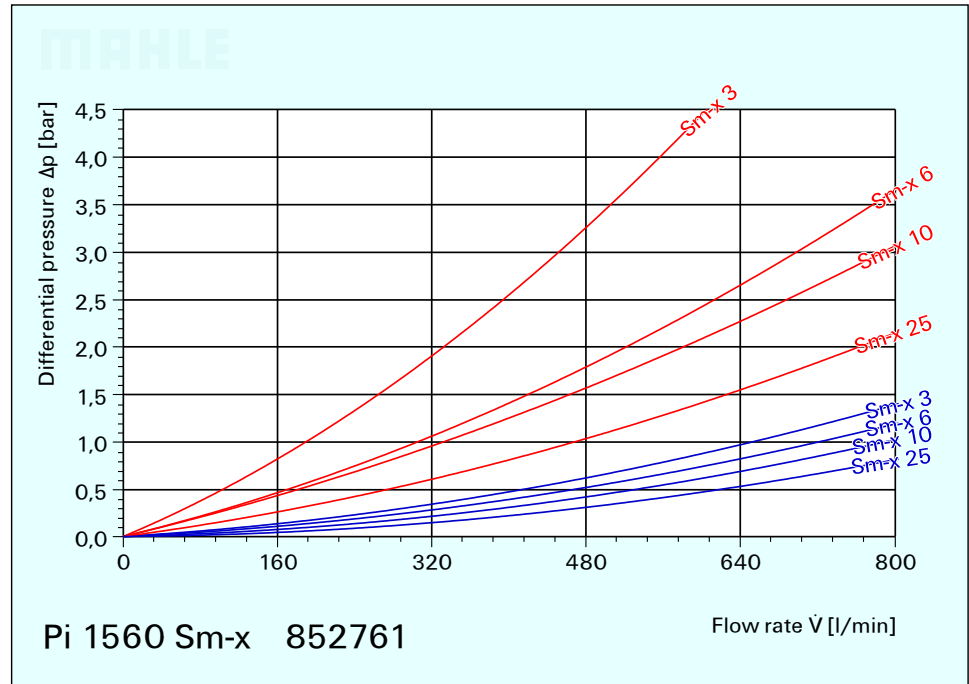
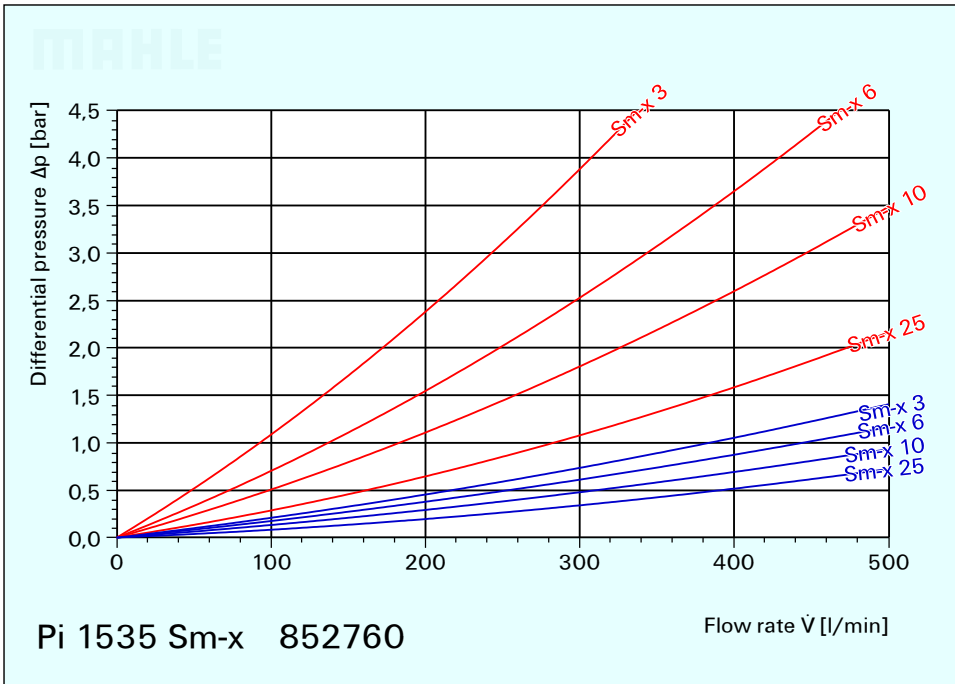
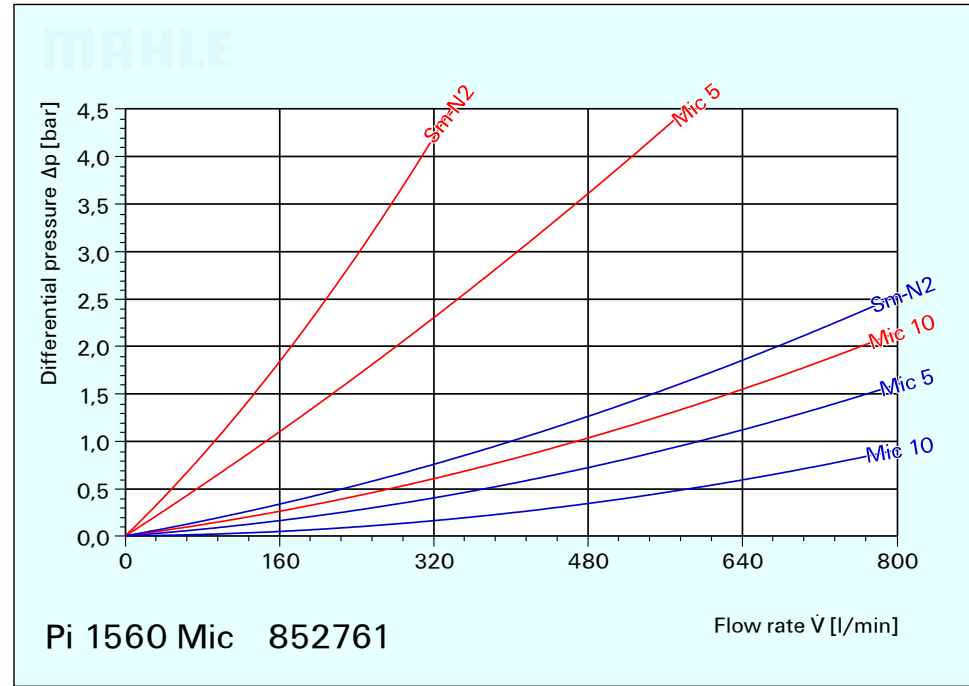
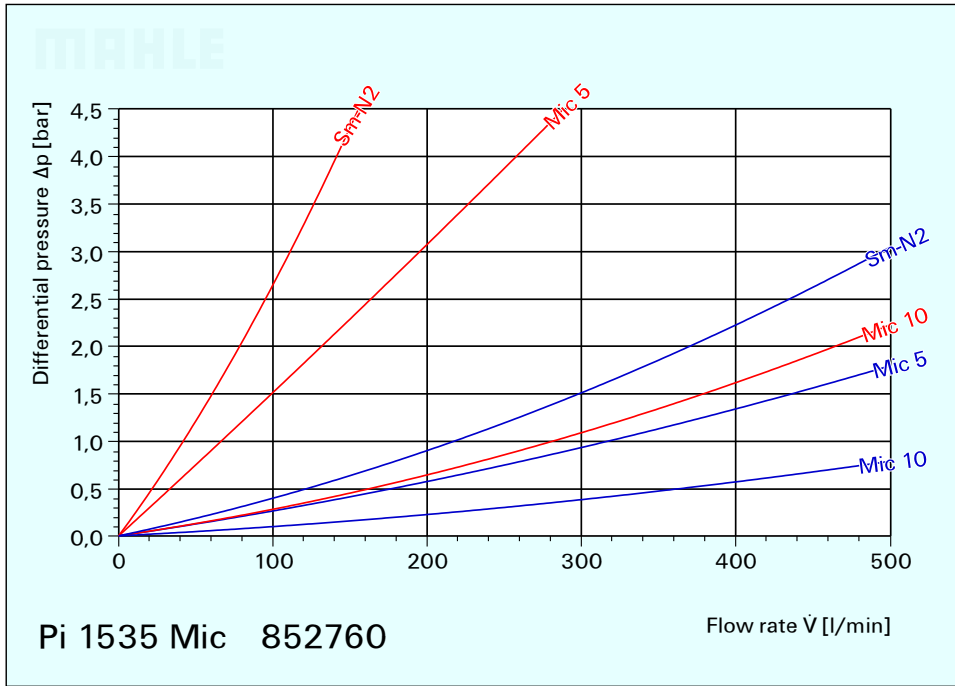

190 mm²/s (25 °E)
33 mm²/s (4,5 °E)

3. Separation characteristics

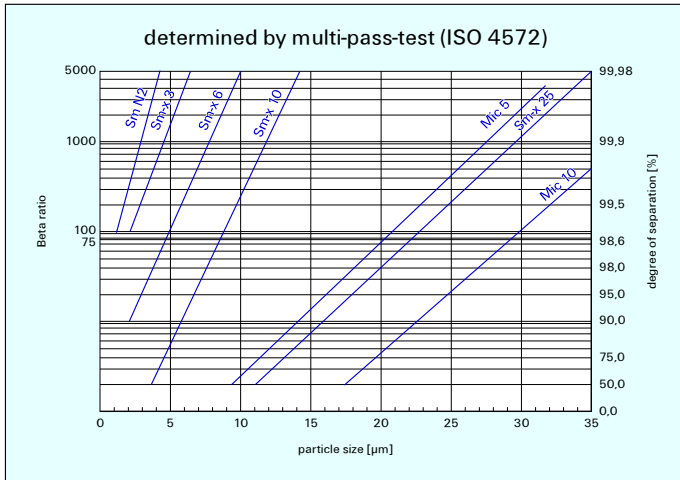

4. Filter performance data

tested according to ISO 4572 (multi-pass-test)

Sm-x-Elements
with Δp 10 bar

Sm-x 3 $\beta_3 \geq 75$

Sm-x 6 $\beta_6 \geq 75$

Sm-x 10 $\beta_{10} \geq 75$

Sm-x 25 $\beta_{25} \geq 75$

at 5 bar differential pressure

The filter element 852 76_ Sm N2 is an element with a very large dirt holding capacity, especially for bypass filtration.

Example for ordering filters:

1. Housing design

\dot{V} = 400 l/min, bypass, electrical indication, nominal pressure 10 bar

Type-no. Pi 1535/10-058 · Order-no. 777.463.1

+ 2. Filter element

Sm-x 10

Type-no. 852 760 Sm-x 10 · Order-no. 777.442.5

7. Part Numbers

7.1 Housing design

Order-number	Type number	Nominal pressure [bar]	Nominal size NG [l/min]	① with bypass valve with visual indicator	② with bypass valve with electrical indicator	③ with visual indicator	④ with electrical indicator	
777.464.9	Pi 1535/10-057	10	400					
777.463.1	Pi 1535/10-058							
780.490.9	Pi 1535/10-068							
780.491.7	Pi 1535/10-069							
795.598.2	Pi 1535/25-057	25						
790.789.2	Pi 1535/25-058							
777.462.3	Pi 1560/10-057	10		630				
777.461.5	Pi 1560/10-058							
780.494.1	Pi 1560/10-068							
780.495.8	Pi 1560/10-069							
795.599.0	Pi 1560/25-057	25						
797.071.8	Pi 1560/25-058							

When filter with non bypass configuration is selected, the collapse pressure of the element may not be exceeded.

5. Test regulations

MAHLE filter elements are manufactured respectively, tested in accordance with the following international standards:

No.	Designation
ISO 2941	Hydraulic-filter elements: Verification of burst resistance
ISO 2942	Hydraulic-filter elements: Determination of fabrication integrity
ISO 2943	Hydraulic-filter elements: Verification of material compatibility with hydraulic fluids
ISO 3723	Hydraulic-filter elements: Method for testing end-cap load
ISO 3724	Hydraulic-filter elements: Verification of flow fatigue characteristics
ISO 39682	Hydraulic-filters: Evaluation of pressure drop versus flow
ISO 4572	Hydraulic-filter elements: Testing of filter performance (multi-pass-test)

6. Symbols

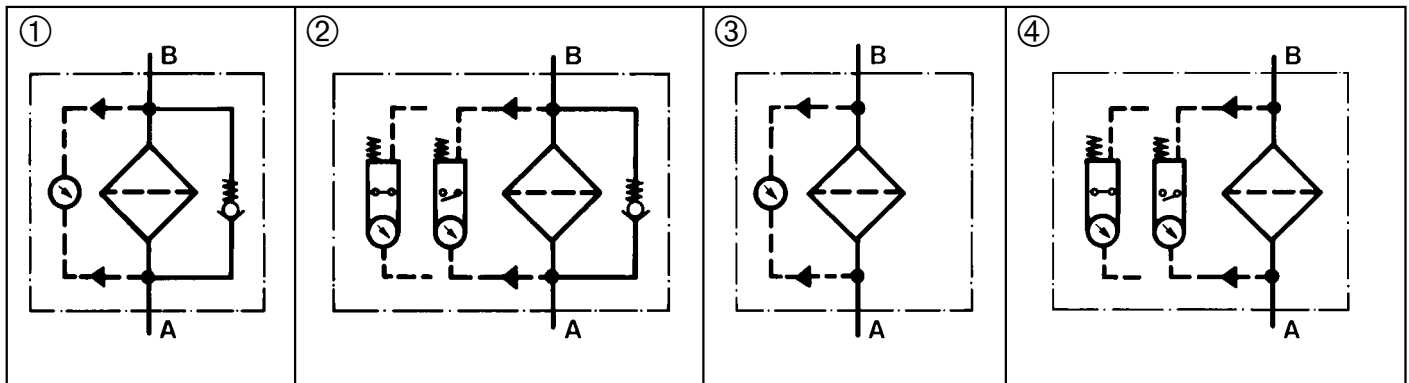

7.2 Filter elements*

() = filter surface [] = order number

	Mic 5 Δp 5 bar	Mic 10 Δp 5 bar	Sm N2 Δp 5 bar	Sm-x 3 Δp 10 bar	Sm-x 6 Δp 10 bar	Sm-x 10 Δp 10 bar	Sm-x 25 Δp 10 bar
}	(23800 cm ²)	(23800 cm ²)	(15900 cm ²)	(14500 cm ²)	(14500 cm ²)	(14500 cm ²)	(14500 cm ²)
	777.445.8	777.444.1	795.585.9	777.443.3	829.904.2	777.442.5	780.656.5
	[852 760 Mic 5]	[852 760 Mic 10]	[852 760 Sm N2]	[852 760 Sm-x 3]	[852 760 Sm-x 6]	[852 760 Sm-x 10]	[852 760 Sm-x 25]
}	(47600 cm ²)	(47600 cm ²)	(31800 cm ²)	(29000 cm ²)	(29000 cm ²)	(29000 cm ²)	(29000 cm ²)
	777.441.7	777.440.9	837.586.7	777.439.1	822.589.8	777.438.3	780.657.3
	[852 761 Mic 5]	[852 761 Mic 10]	[852 761 Sm N2]	[852 761 Sm-x 3]	[852 761 Sm-x 6]	[852 761 Sm-x 10]	[852 761 Sm-x 25]

*further elements available upon request

8. Specifications

Nominal pressure:	10/25 bar*
Temperature range:	-10 °C bis +120 °C (other temperature ranges on request)
Bypass valve opening pressure:	Δp 3,5 bar \pm 10 %
Filter head material:	GDAI
Filter bowl material:	St (steel)
Sealing material:	NBR
Activating pressure of visual/electrical differential pressure indicator:	Δp 2,2 bar \pm 10 %
Electrical data of differential pressure indicator:	
Maximum voltage:	230 V \sim / =
Maximum current on contact:	2,5 A
Maximum contact load:	60 VA / 40 W
Inrush current:	70 VA
Type of protection:	IP 65 when inserted and secured
Contact:	bistable
Cable connection:	PG 11 \varnothing 6-10

The electrical indicator function can be changed from the Normally Open position to the Normally Closed position or visa versa by inverting the electrical section.

With the inrush current of 70 VA the indicator can trigger small contactors or contactor relays.

Inductivity in the direct current may require the use of a signal eraser.

For further information and executions please see our leaflet "contamination indicators".

Filters compatible with standard mineral oils.

Please contact us in case of using other media.

Housings with nominal pressure 10 bar are fitted standard with an air bleeder valve, housings with nominal pressure 25 bar with a venting screw.

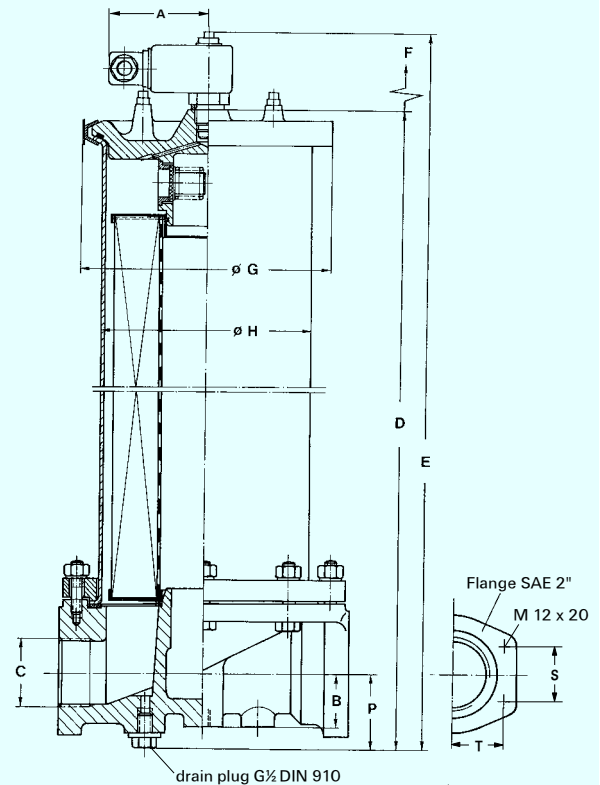
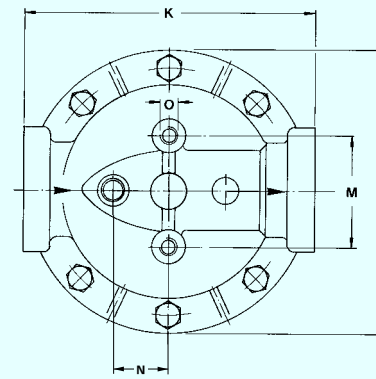

9. Dimensions

All dimensions (except "C" and "O") in mm

Dimension	Type	
	Pi 1535	Pi 1560
A	78	78
B	42	42
C	G 1½	SAE 2"*
D	607	1035
E	643	1068
F	425	850
G	190	190
H	164	164
I	225	225
K	230	230
M	90	90
N	44	44
O	M 12 x 20	M 12 x 20
P	59	59
R	45	45
S	-	42,9
T	-	77,8
Weight	17,1 kg	27,1 kg

*Standard pressure series hole pattern 3000 PSI

10. Installation, operating and maintenance instructions

10.1 Filter installation

When installing the filter make sure that sufficient space is available to remove filter element.
The contamination indicator must be visible.

10.2 Connecting the electrical contamination indicator

The electrical indicator is connected via a 2-pole appliance plug according to DIN 43650 with poles marked 1 and 2.
The electrical section can be inverted to change from Normally Open position to Normally Closed position or visa versa.

10.3 When must the filter element be replaced?

- Filters equipped with visual and electrical contamination indicator:
During cold starts, the indicator may give a warning signal. Depress the red button of the visual indicator once again only after operating temperature has been reached. If the red button immediately pops out again and/or the electrical signal has not switched off after reaching operating temperature, the filter element must be replaced after the end of the shift.
- Filters without contamination indicator:
The filter element should be replaced after the trial run or flushing of the system. Afterwards follow instructions of the manufacturer.
- Please always ensure that you have original MAHLE-replacement elements in stock: disposable elements Mic or Sm-x cannot be cleaned.

10.4 Element replacement

- Stop system and relieve filter from pressure.
- Loosen quick-action clamp, remove cover, and open drain valve. Housing completely vented.
- Remove filter element from the filter bowl.
- Check seal for damages, replace if necessary.
- Make sure that the part number on the spare element corresponds with the part number on the filter label. Remove the plastic bag and push element over the spigot in the filter head.
- Close drain valve, relocate cover, and close the quick-action clamp. Filters are automatically vented via the air bleeder valve (10 bar version), the protection cap S has to be turned 2 times for being open.

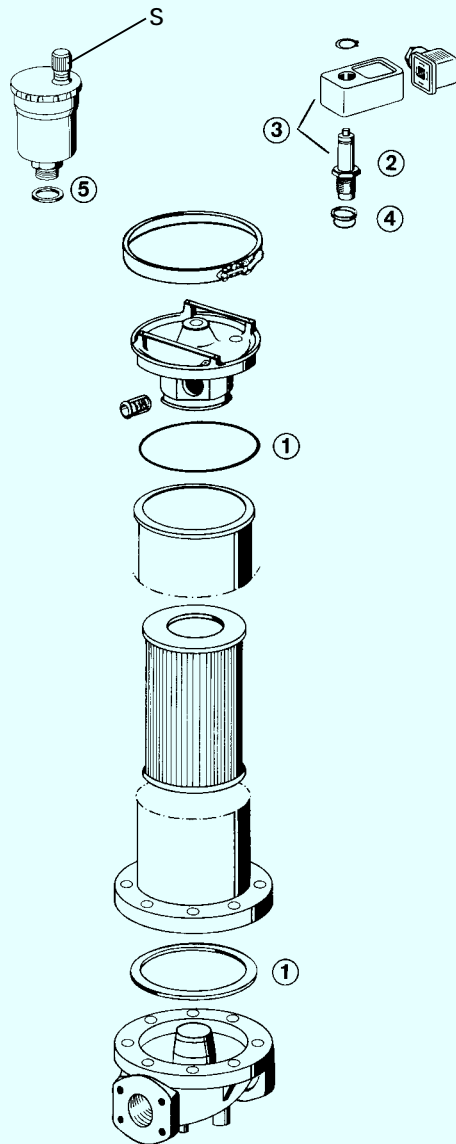

11. Spare Parts List

Pos.	Housing design
①	Seal kit NBR 783.140.7 FPM 783.141.5 EPDM 783.142.3
②	Differential pressure indicator visual visual/electrical 766.997.1 766.994.8 Pis 3098 / 2,2 Pis 3097 / 2,2
④	Seal kit for differential pressure indicator Pis 3098 / 2,2 + Pis 3097/2,2 NBR 776.030.9 FPM 776.031.7 EPDM 776.032.5
⑤	Air bleeder valve 935.251.9

Subject to technical alteration without prior notice.

MAHLE

MAHLE Filtersysteme GmbH

Bereich Industriefilter · Schleifbachweg 45 · D-74613 Öhringen · Postfach 13 09 · D-74603 Öhringen
Telefon (0 79 41) 67-0 · Telefax (0 79 41) 67-429 · Internet: <http://www.mahle.com> · E-mail: ub2.industrie@mahle.com