

## Low Pressure Filter

### Pi 220

Operating pressure 10 bar, Nominal size up to 160

#### 1. Features

##### Efficient filters for modern hydraulic systems

---

- Modular design
  - Minimal pressure loss
  - Compact design
  - Visual / electrical / electronic differential pressure indication
  - Threaded ports
- 

##### Quality filters, easy to service

---

- Highly efficient Mic- or Sm-x-filter elements
  - $\beta$ -rated elements per ISO 4572
  - Large dirt holding capacity and high differential pressure stability providing optimal element service life
- 

##### World-wide sales



## 2. Flow rate/pressure drop curve compl. filter

■ 190 mm<sup>2</sup>/s (25 ° E)  
■ 33 mm<sup>2</sup>/s (4,5 ° E)

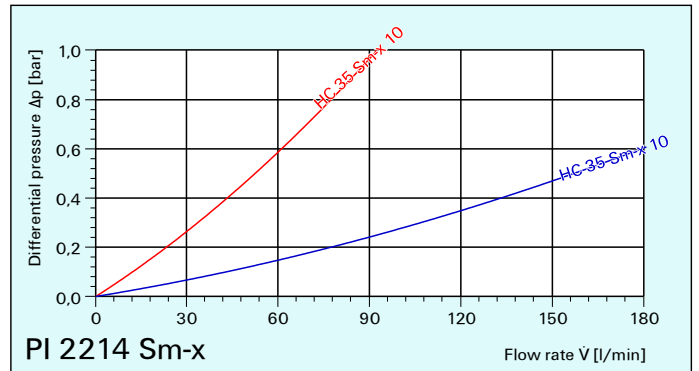
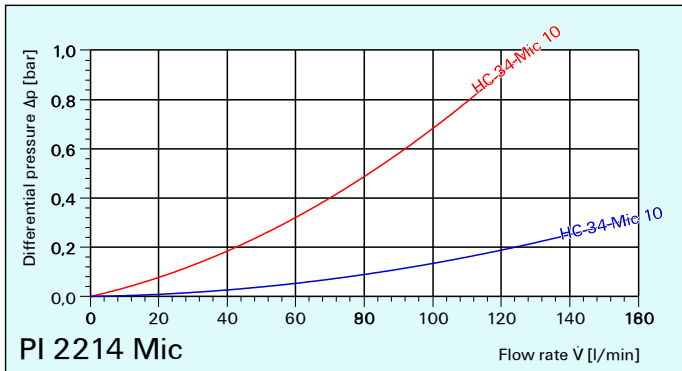
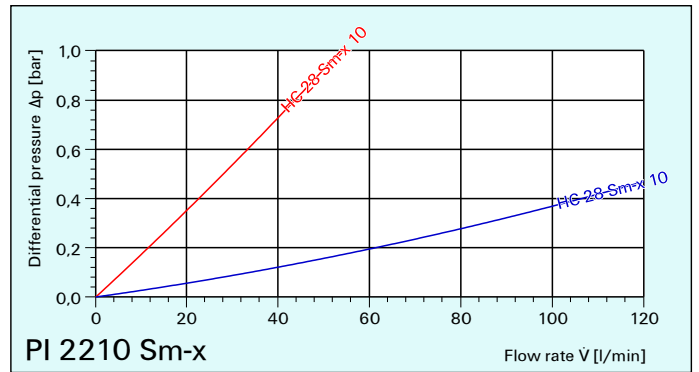
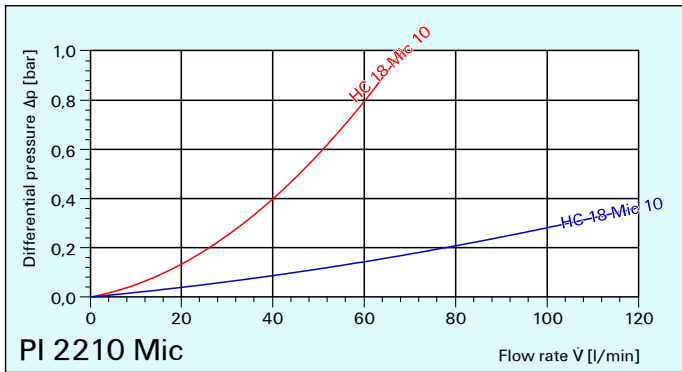
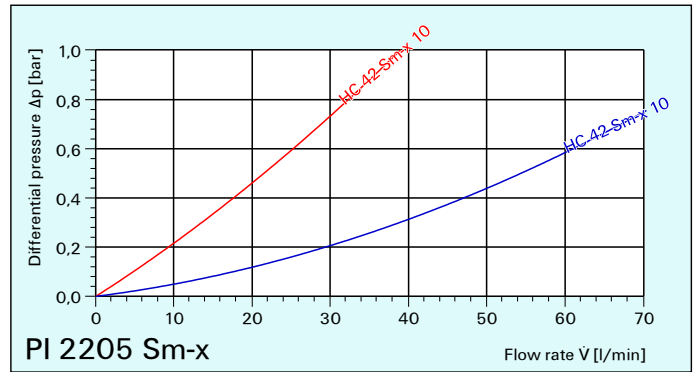
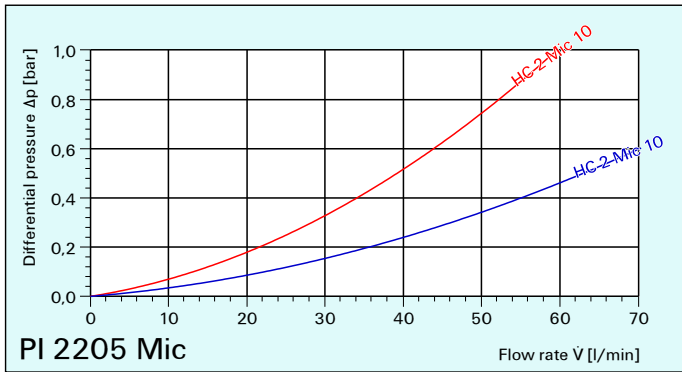
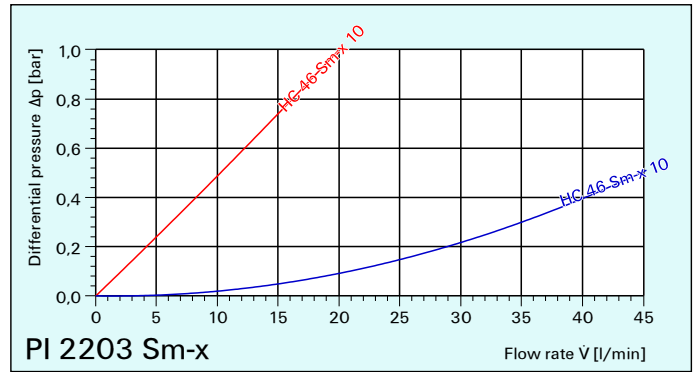
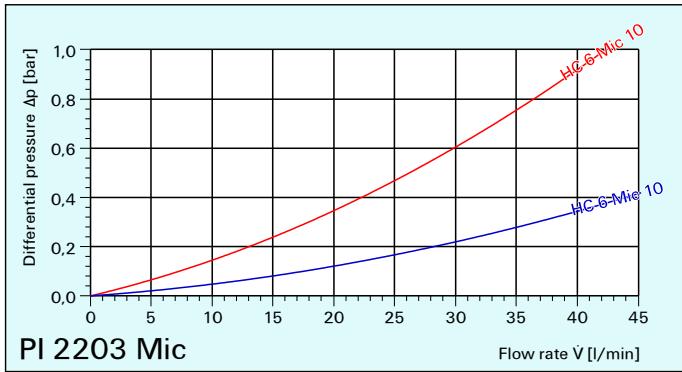
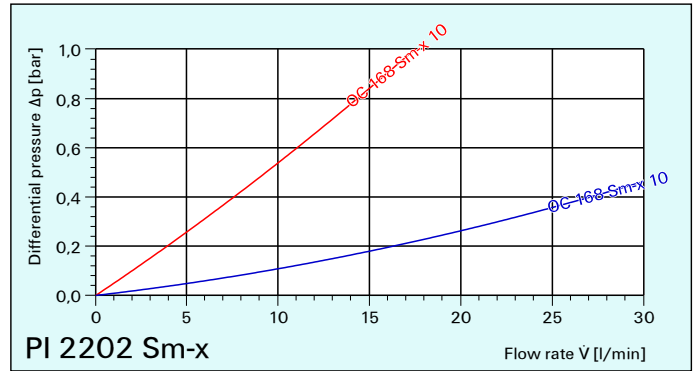
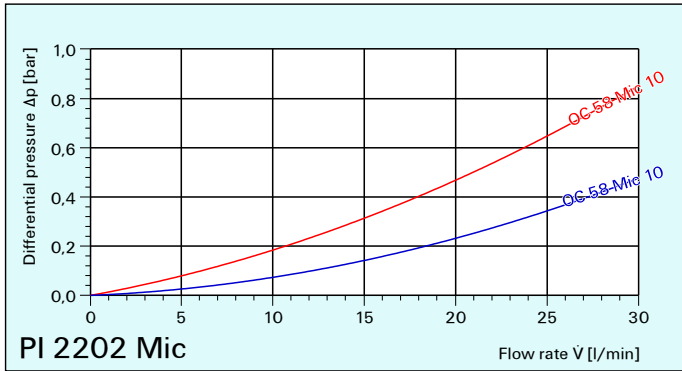

### 3. Separation characteristics

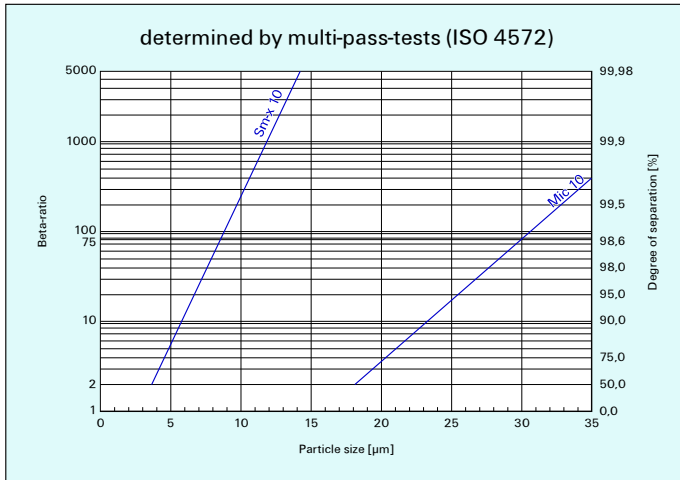

### 4. Symbols

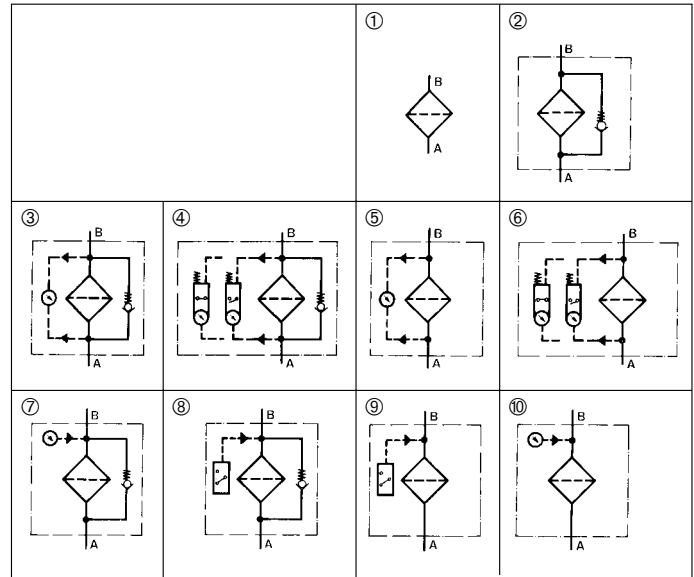

### 5. Test regulations

MAHLE filter elements are manufactured respectively, tested in accordance with the following international standards:

No.	Designation
ISO 2941	Hydraulic-filter elements: Verification of burst resistance
ISO 2942	Hydraulic-filter elements: Determination of fabrication integrity
ISO 2943	Hydraulic-filter elements: Verification of material compatibility with hydraulic fluids
ISO 3723	Hydraulic-filter elements: Method for testing end-cap load
ISO 3724	Hydraulic-filter elements: Verification of flow fatigue characteristics
ISO 3968.2	Hydraulic-filters: Evaluation of pressure drop versus flow
ISO 4572	Hydraulic-filter elements: Testing of filter performance (multi-pass-test)

**Example for ordering filter:** 1. Housing design  $\dot{V} = 25$  l/min, bypass, electrical contamination indicator  
Type-no. **PI 2202-58**

Order-no. **766.564.9**

+ 2. Spin-on cartridge Mic 10  
Type-no. **OC 58**

Order-no. **778.598.3**

## 6. Order numbers for pressure-side installation

## 7. Order numbers for suction-side installation

6.1 Housing design			6.2 Spin-on cartridges								7.1 Housing design								
Order Number	Type number	Nominal size (NG)	①	②	③	④	⑤	⑥	Mic 10 $\Delta p$ 5 bar (1700 cm <sup>2</sup> )	Sm-x 10 $\Delta p$ 5 bar (1200 cm <sup>2</sup> )	⑩	⑨	⑧	⑦	②	①	Nominal size (NG)	Type number	Order number
			*Standard	with bypass valve	with bypass valve and visual indicator	with bypass valve and visual / electrical indicator	with visual indicator	with visual / electrical indicator			with vacuum gauge	with vacuum switch	with bypass 0.25 bar and vacuum switch	with bypass 0.25 bar and vacuum gauge	with bypass 0.25 bar	* without anything			
766.565.6	Pi 2202-60	<b>25</b>							(1700 cm <sup>2</sup> )	(1200 cm <sup>2</sup> )							<b>10</b>	Pi 2202-60	766.565.6
766.562.3	Pi 2202-56								778.598.3	750.018.4								Pi 2202-67	773.661.4
766.563.1	Pi 2202-57								[OC 58]	[OC 168]								Pi 2202-62	773.662.2
766.564.9	Pi 2202-58																	Pi 2202-61	773.663.0
766.566.4	Pi 2202-68								778.598.3									Pi 2202-65	773.660.6
766.567.2	Pi 2202-69																	Pi 2202-66	773.659.8
766.571.4	Pi 2203-60	<b>40</b>							(3200 cm <sup>2</sup> )	(2100 cm <sup>2</sup> )							<b>16</b>	Pi 2203-60	766.571.4
766.568.0	Pi 2203-56								750.127.3	750.123.2								Pi 2203-67	766.573.0
766.569.8	Pi 2203-57								[HC 6]	[HC 46]								Pi 2203-62	773.668.9
766.570.6	Pi 2203-58																	Pi 2203-61	773.669.7
766.574.8	Pi 2203-68								750.127.3									Pi 2203-65	773.667.1
766.575.5	Pi 2203-69																	Pi 2203-66	766.572.2
766.581.3	Pi 2205-60	<b>63</b>							(5100 cm <sup>2</sup> )	(3300 cm <sup>2</sup> )							<b>25</b>	Pi 2205-60	766.581.3
766.578.9	Pi 2205-56								201.324.1	750.137.2								Pi 2205-67	773.674.7
766.579.7	Pi 2205-57								[HC 2]	[HC 42]								Pi 2205-62	766.582.1
766.580.5	Pi 2205-58																	Pi 2205-61	773.675.4
766.584.7	Pi 2205-68								201.324.1									Pi 2205-65	766.583.9
766.585.4	Pi 2205-69																	Pi 2205-66	773.673.9
766.600.1	Pi 2210-60	<b>100</b>							(7000 cm <sup>2</sup> )	(4100 cm <sup>2</sup> )							<b>40</b>	Pi 2210-60	766.600.1
766.597.9	Pi 2210-56								764.333.1	764.339.8								Pi 2210-67	773.594.7
766.598.7	Pi 2210-57								[HC 18]	[HC 28]								Pi 2210-62	766.602.7
766.599.5	Pi 2210-58																	Pi 2210-61	766.601.9
766.605.0	Pi 2210-68								764.333.1									Pi 2210-65	766.603.5
766.606.8	Pi 2210-69																	Pi 2210-66	766.604.3
766.612.6	Pi 2214-60	<b>160</b>							(13500 cm <sup>2</sup> )	(7500 cm <sup>2</sup> )							<b>63</b>	Pi 2214-60	766.612.6
766.609.2	Pi 2214-56								750.419.4	764.384.4								Pi 2214-67	766.617.5
766.610.0	Pi 2214-57								[HC 34]	[HC 35]								Pi 2214-62	766.614.2
766.611.8	Pi 2214-58																	Pi 2214-61	766.613.4
766.618.3	Pi 2214-68								750.419.4									Pi 2214-65	766.615.9
766.619.1	Pi 2214-69																	Pi 2214-66	766.616.7

\*When filters are used without bypass it must be ascertained that  $\Delta p = 5$  bar is not exceeded.

## 8. Specifications

Design:	line mounting filter
Nominal pressure:	10 bar*
Test pressure:	13 bar
Temperature range:	-10 °C to +120 °C (other temperature ranges on request)
Bypass opening pressure:	
pressure side:	$\Delta p$ 3,5 bar
suction side:	$\Delta p$ 0,25 bar
Filter head material:	GDAL
Spin-on-cartridge material:	St
Material of seals:	NBR / AL
Activating pressure of visual / electrical differential pressure indicator:	$\Delta p$ 2,2 bar $\pm$ 0,3 bar
Indicating range vacuummeter:	-1 bar to +1,5 bar
Pressure setting vacuum switch:	200 mbar
Electrical data of contamination indicator:	
Maximum voltage:	230 V $\sim$ / =
Maximum current on contact:	2,5 A
Maximum contact load:	60 VA / 40 W
Inrush current:	70 VA
Type of protection:	IP 65 when inserted and secured
Contact:	bistable
Cable connection:	PG 11 $\varnothing$ 6-10

The electrical indicator function can be changed from the Normally Open position to the Normally Closed position or visa versa by inverting the electrical section.

With the inrush current of 70 VA the indicator can trigger small contactors or contactor relays.

Inductivity in the direct current may require the use of a signal eraser.

For further information also see our leaflet "contamination indicators".

Spin-on cartridges are compatible with standard mineral oils.

Please contact us in case of using other media.

\* For the combination of the housing designs as per 6.1 with medium-pressure Spin-on cartridges at 25 bar pressure refer to leaflet "Spin-on cartridges" for dimensions and specifications.

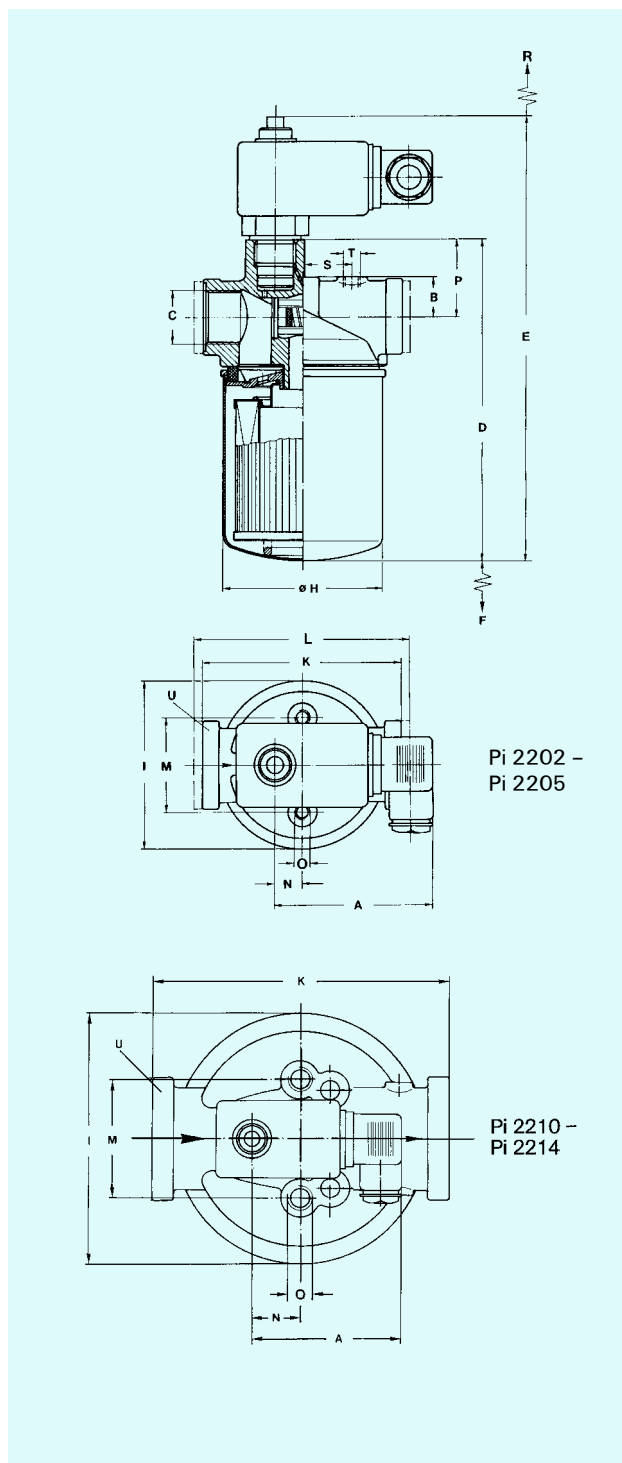

## 9. Dimensions

All dimensions (except „C“ and „T“) in mm

Dimension Type	A	B	C	D	E	F	G	H	I	K	L	M	N	O	P	R	S*	T*	U SW	Weight
	Pi 2202	78	19	G ½	181	241	30	-	76	80	-	109	45	13	M 8 x 10	37,5	45	23,5	G ½	36
Pi 2203	78	19	G ½	201	261	30	-	93	95	-	109	45	13	M 8 x 10	37,5	45	23,5	G ½	36	1,0 kg
Pi 2205	78	19	G ¾	268	328	30	-	93	95	95	-	45	13	M 8 x 10	37,5	45	23,5	G ¾	36	1,25 kg
Pi 2210	78	30	G 1 ¼	242	302	40	-	137	143	150	-	60	24,5	M 12 x 15	43,5	45	40	G ¾	55	2,3 kg
Pi 2214	78	30	G 1 ¼	382	442	40	-	137	143	150	-	60	24,5	M 12 x 15	43,5	45	40	G ¾	55	2,7 kg

\*with suction-side installation only

## 10. Installation, operating and maintenance instructions

### 10.1 Filter installation

When installing the filter make sure that sufficient space is available to remove the spin-on cartridge. Preferably the filter should be installed with the spin-on cartridge pointing downwards. The contamination indicator must be visible.

### 10.2 Connecting the electrical contamination indicator

The electrical indicator is connected via a 2-pole appliance plug according to DIN 43650 with poles marked 1 and 2. The electrical section can be inverted to change from Normally Open position to Normally Closed position or visa versa.

### 10.3 When must the spin-on cartridge be replaced?

- Filters equipped with the visual and electrical contamination indicator:  
During cold starts, the indicator may give a warning signal. Depress the red button of the visual indicator once again only after operating temperature has been reached. If the red button immediately pops out again and/or the electrical signal has not switched off after reaching operating temperature, the spin-on cartridge must be replaced after the end of the shift.
- Filters without contamination indicator:  
The spin-on cartridge should be replaced after the trial run or flushing of the system. Afterwards follow instructions of the manufacturer.
- Please always ensure that you have original MAHLE-replacement cartridges in stock.

### 10.4 Change of spin-on cartridge

- Stop plant and relieve filter from pressure.
- Unscrew the spin-on cartridge with the aid of a belt spanner by turning same to the left.
- Check if the part number on the new spin-on cartridge is identical with that of the type plate.
- The seal of the screw-on cartridge should be lightly oiled.
- Screw cartridge on in accordance with the printed-on instructions.

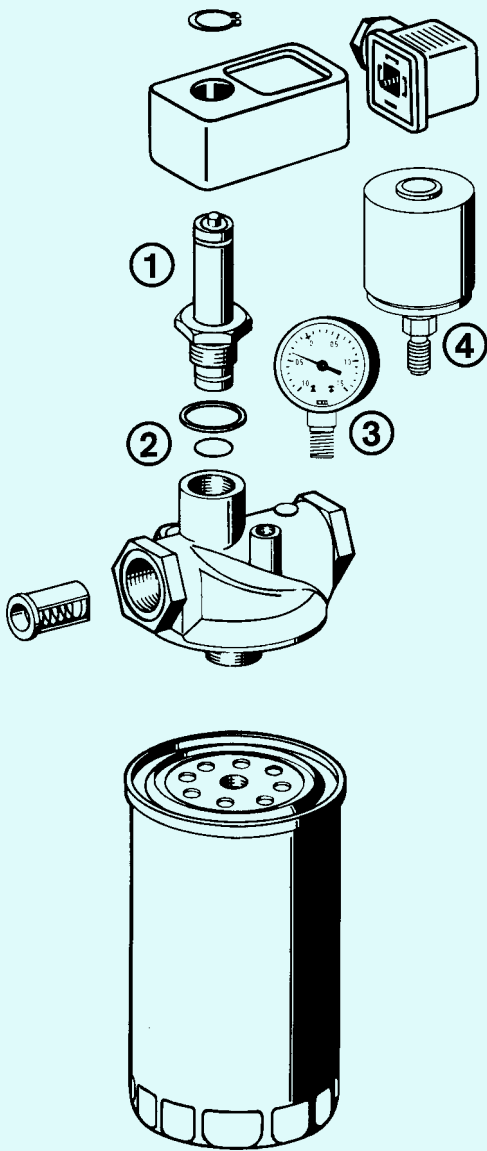

## 11. Spare parts list

Pos.	Order-No./Type-No.		
①	Contamination indicator		
	visual	electrical	electrical section only
	766.997.1 Pis 3098	766.994.8 Pis 3097	753.655.0
②	Seal set for contamination indicator NBR 776.030.9		
③	Vacuum meter 754.802.7		
④	Vacuum switch 766.972.4		

Subject to technical alteration without prior notice.

# MAHLE

MAHLE Filtersysteme GmbH

Bereich Industriefilter · Schleifbachweg 45 · D-74613 Öhringen · Postfach 13 09 · D-74603 Öhringen  
Telefon (0 79 41) 67-0 · Telefax (0 79 41) 67-429 · Internet: <http://www.mahle.com> · E-mail: [ub2.industrie@mahle.com](mailto:ub2.industrie@mahle.com)