

## Medium Pressure Filter

### Pi 3000

Operating pressure 200 (315) bar, Nominal size up to 400  
according to DIN 24550

#### 1. Features

##### Efficient filters for modern hydraulic systems

- Modular design
- Minimal pressure loss
- Compact design
- Visual / electrical / electronical differential pressure indication
- Threaded ports

##### Quality filters, easy to service

- Highly efficient Sm-x filter elements
- $\beta$ -rated elements per ISO 4572
- Large dirt holding capacity and high differential pressure stability providing optimal element service life

##### World-wide sales



## 2. Flow rate / pressure drop curve compl. filter

■ 190 mm<sup>2</sup>/s (25 ° E)  
■ 33 mm<sup>2</sup>/s (4,5 ° E)

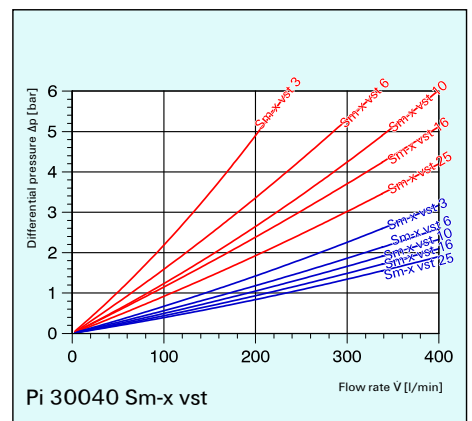
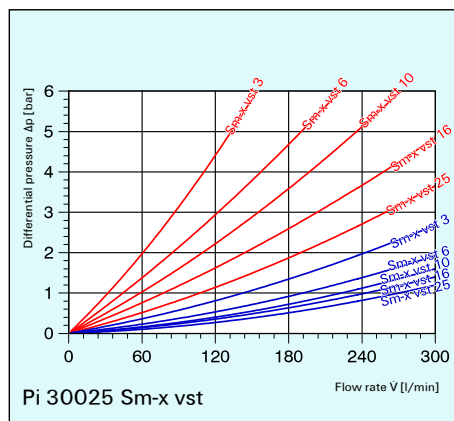
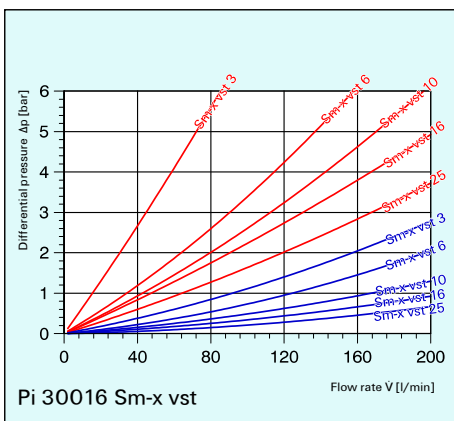
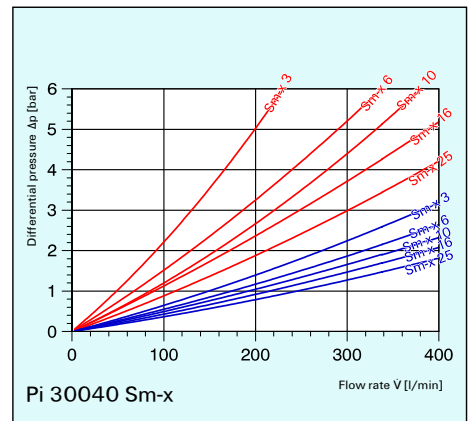
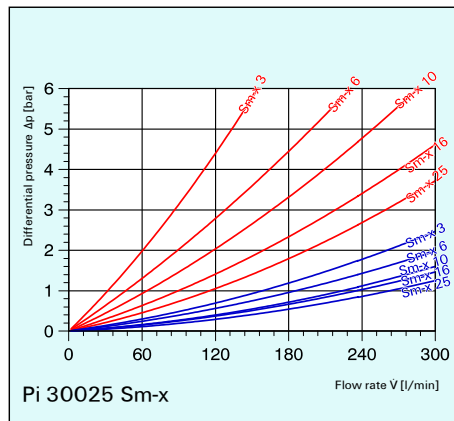
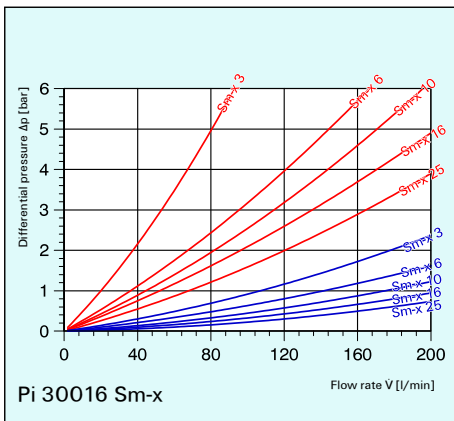
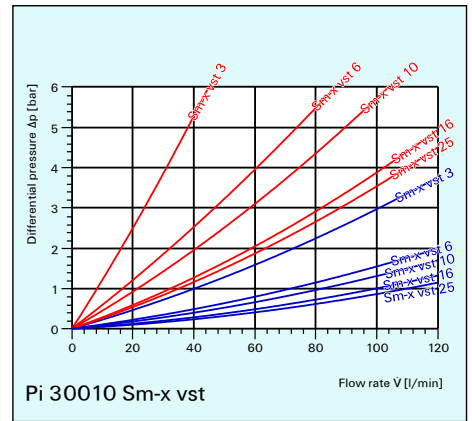
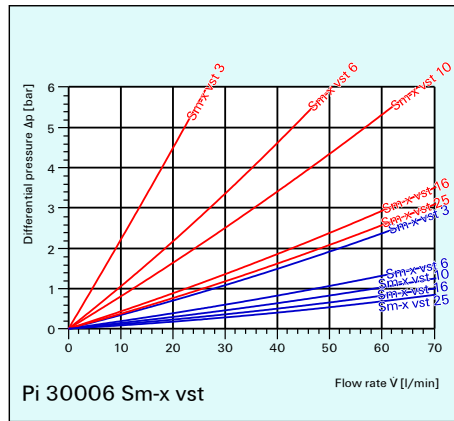
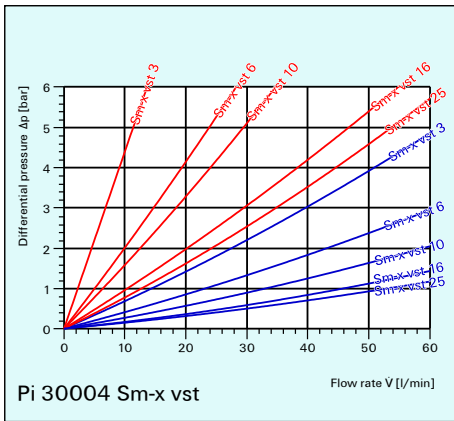
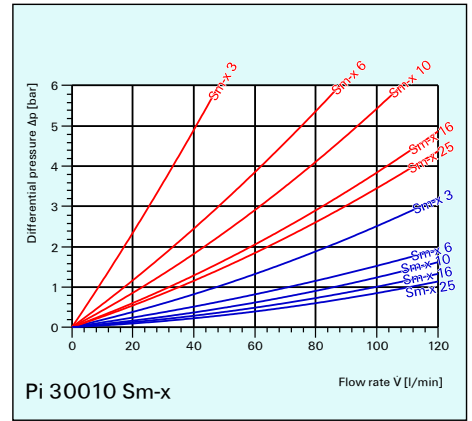
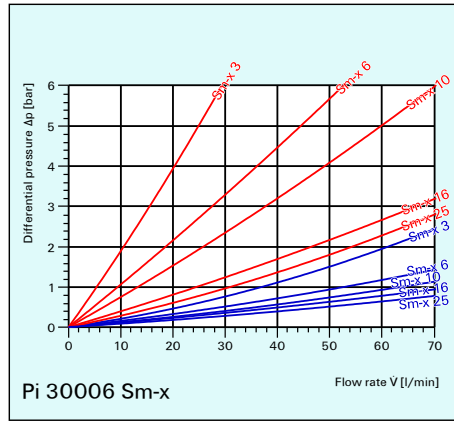
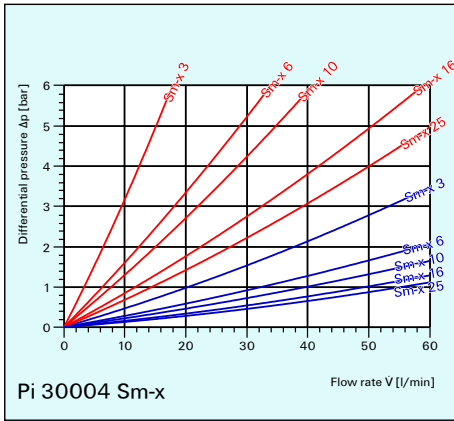

### 3. Separation characteristics

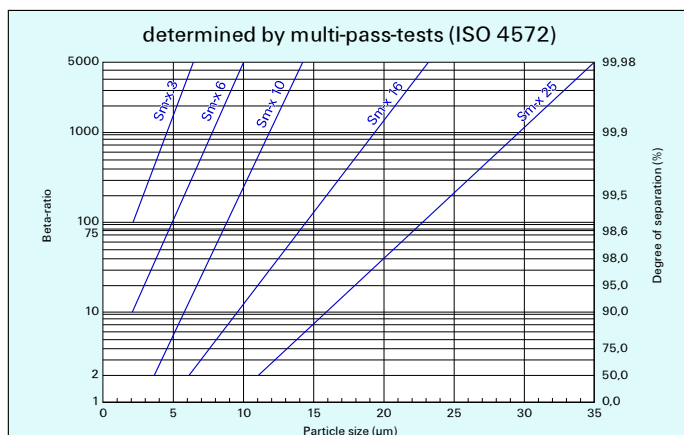

### 4. Filter performance data

tested according to ISO 4572 (Multi-Pass-Test)

Sm-x elements  
with  $\Delta p$  20 bar

Sm-x 3  $\beta_3 \geq 75$   
 Sm-x 6  $\beta_6 \geq 75$   
 Sm-x 10  $\beta_{10} \geq 75$   
 Sm-x 16  $\beta_{16} \geq 75$   
 Sm-x 25  $\beta_{25} \geq 75$

at 7 bar differential pressure

Sm-x vst elements  
with  $\Delta p$  210 bar

Sm-x vst 3  $\beta_3 \geq 75$   
 Sm-x vst 6  $\beta_6 \geq 75$   
 Sm-x vst 10  $\beta_{10} \geq 75$   
 Sm-x vst 16  $\beta_{16} \geq 75$   
 Sm-x vst 25  $\beta_{25} \geq 75$

at 16 bar differential pressure

#### Example for ordering filters:

1. Housing design  $\dot{V} = 100$  l/min, electrical indicator  
 Type-no. **Pi 30 010-15** Order-no. **820.808.4**
- +2. Filter element Sm-x vst 3  
 Type-no. **Pi 71 010 DN** Order-no. **822.748.0**

### 7. Order numbers

#### 7.1 Housing design

Part number	Type number	Nominal size (NG)	① With indicator cavity	② With bypass valve and indicator cavity	③ With bypass valve and visual indicator	④ With bypass valve and electrical indicator	⑤ With visual indicator	⑥ With electrical indicator
820.789.6	Pi 30 004-010	<b>40</b>						
820.790.4	Pi 30 004-011							
833.738.8	Pi 30 004-012							
830.420.6	Pi 30 004-013							
820.793.8	Pi 30 004-014							
820.794.6	Pi 30 004-015							
820.796.1	Pi 30 006-010	<b>63</b>						
820.797.9	Pi 30 006-011							
820.798.7	Pi 30 006-012							
830.421.4	Pi 30 006-013							
820.800.1	Pi 30 006-014							
820.801.9	Pi 30 006-015							
820.803.5	Pi 30 010-010	<b>100</b>						
820.804.3	Pi 30 010-011							
820.805.0	Pi 30 010-012							
830.422.2	Pi 30 010-013							
820.807.6	Pi 30 010-014							
820.808.4	Pi 30 010-015							
820.810.0	Pi 30 016-010	<b>160</b>						
820.811.8	Pi 30 016-011							
820.812.6	Pi 30 016-012							
825.997.0	Pi 30 016-013							
820.814.2	Pi 30 016-014							
820.815.9	Pi 30 016-015							
820.816.7	Pi 30 025-010	<b>250</b>						
820.817.5	Pi 30 025-011							
820.818.3	Pi 30 025-012							
825.998.8	Pi 30 025-013							
820.820.9	Pi 30 025-014							
820.821.7	Pi 30 025-015							
820.822.5	Pi 30 040-010	<b>400</b>						
820.823.3	Pi 30 040-011							
820.824.1	Pi 30 040-012							
825.999.6	Pi 30 040-013							
820.826.6	Pi 30 040-014							
820.827.4	Pi 30 040-015							

When filter with non bypass configuration is selected the collapse pressure of the element may not be exceeded.

## 5. Test regulations

MAHLE filter elements are manufactured respectively, tested in accordance with the following international standards:

No.	Designation
ISO 2941	Hydraulic-filter elements: Verification of burst resistance
ISO 2942	Hydraulic-filter elements: Determination of fabrication integrity
ISO 2943	Hydraulic-filter elements: Verification of material compatibility with hydraulic fluids
ISO 3723	Hydraulic-filter elements: Method for testing end-cap load
ISO 3724	Hydraulic-filter elements: Verification of flow fatigue characteristics
ISO 3968.2	Hydraulic-filters: Evaluation of pressure drop versus flow
ISO 4572	Hydraulic-filter elements: Testing of filter performance (multi-pass-test)

## 6. Symbols

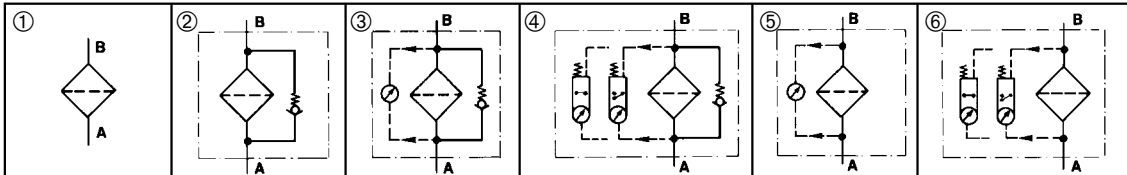

## 7.2 Filter elements\* ( ) = Filter surface area [ ] = Type number

Sm-x 3 Δp 20 bar	Sm-x 6 Δp 20 bar	Sm-x 10 Δp 20 bar	Sm-x 16 Δp 20 bar	Sm-x 25 Δp 20 bar	Sm-x vst 3 Δp 210 bar	Sm-x vst 6 Δp 210 bar	Sm-x vst 10 Δp 210 bar	Sm-x vst 16 Δp 210 bar	Sm-x vst 25 Δp 210 bar
(540 cm <sup>2</sup> )	(540 cm <sup>2</sup> )	(540 cm <sup>2</sup> )	(540 cm <sup>2</sup> )	(540 cm <sup>2</sup> )	(440 cm <sup>2</sup> )	(440 cm <sup>2</sup> )	(440 cm <sup>2</sup> )	(440 cm <sup>2</sup> )	(440 cm <sup>2</sup> )
					[Pi 71 004 DN]	[Pi 72 004 DN]	[Pi 73 004 DN]	[Pi 74 004 DN]	[Pi 75 004 DN]
					821.607.9	796.015.6	792.565.4	821.608.7	821.609.5
[Pi 21 004 DN]	[Pi 22 004 DN]	[Pi 23 004 DN]	[Pi 24 004 DN]	[Pi 25 004 DN]					
826.092.9	796.085.9	792.557.1	826.093.7	826.094.5					
(910 cm <sup>2</sup> )	(910 cm <sup>2</sup> )	(910 cm <sup>2</sup> )	(910 cm <sup>2</sup> )	(910 cm <sup>2</sup> )	(780 cm <sup>2</sup> )	(780 cm <sup>2</sup> )	(780 cm <sup>2</sup> )	(780 cm <sup>2</sup> )	(780 cm <sup>2</sup> )
					[Pi 71 006 DN]	[Pi 72 006 DN]	[Pi 73 006 DN]	[Pi 74 006 DN]	[Pi 75 006 DN]
					821.613.7	796.014.9	792.566.2	821.614.5	821.615.2
[Pi 21 006 DN]	[Pi 22 006 DN]	[Pi 23 006 DN]	[Pi 24 006 DN]	[Pi 25 006 DN]					
826.096.0	796.086.7	792.558.9	826.097.8	826.098.6					
(1490 cm <sup>2</sup> )	(1490 cm <sup>2</sup> )	(1490 cm <sup>2</sup> )	(1490 cm <sup>2</sup> )	(1490 cm <sup>2</sup> )	(1270 cm <sup>2</sup> )	(1270 cm <sup>2</sup> )	(1270 cm <sup>2</sup> )	(1270 cm <sup>2</sup> )	(1270 cm <sup>2</sup> )
					[Pi 71 010 DN]	[Pi 72 010 DN]	[Pi 73 010 DN]	[Pi 74 010 DN]	[Pi 75 010 DN]
					822.748.0	796.013.1	792.567.0	826.128.1	821.616.0
[Pi 21 010 DN]	[Pi 22 010 DN]	[Pi 23 010 DN]	[Pi 24 010 DN]	[Pi 25 010 DN]					
822.747.2	796.087.5	792.559.7	826.100.0	826.101.8					
(2420 cm <sup>2</sup> )	(2420 cm <sup>2</sup> )	(2420 cm <sup>2</sup> )	(2420 cm <sup>2</sup> )	(2420 cm <sup>2</sup> )	(2030 cm <sup>2</sup> )	(2030 cm <sup>2</sup> )	(2030 cm <sup>2</sup> )	(2030 cm <sup>2</sup> )	(2030 cm <sup>2</sup> )
					[Pi 71 016 DN]	[Pi 72 016 DN]	[Pi 73 016 DN]	[Pi 74 016 DN]	[Pi 75 016 DN]
					794.063.8	796.012.3	792.568.8	826.979.7	821.617.8
[Pi 21 016 DN]	[Pi 22 016 DN]	[Pi 23 016 DN]	[Pi 24 016 DN]	[Pi 25 016 DN]					
826.103.4	796.082.6	792.560.5	826.104.2	826.105.9					
(4020 cm <sup>2</sup> )	(4020 cm <sup>2</sup> )	(4020 cm <sup>2</sup> )	(4020 cm <sup>2</sup> )	(4020 cm <sup>2</sup> )	(3370 cm <sup>2</sup> )	(3370 cm <sup>2</sup> )	(3370 cm <sup>2</sup> )	(3370 cm <sup>2</sup> )	(3370 cm <sup>2</sup> )
					[Pi 71 025 DN]	[Pi 72 025 DN]	[Pi 73 025 DN]	[Pi 74 025 DN]	[Pi 75 025 DN]
					794.064.6	796.011.5	792.569.6	826.981.3	821.618.6
[Pi 21 025 DN]	[Pi 22 025 DN]	[Pi 23 025 DN]	[Pi 24 025 DN]	[Pi 25 025 DN]					
822.751.4	796.083.4	792.561.3	826.107.5	826.108.3					
(6700 cm <sup>2</sup> )	(6700 cm <sup>2</sup> )	(6700 cm <sup>2</sup> )	(6700 cm <sup>2</sup> )	(6700 cm <sup>2</sup> )	(5600 cm <sup>2</sup> )	(5600 cm <sup>2</sup> )	(5600 cm <sup>2</sup> )	(5600 cm <sup>2</sup> )	(5600 cm <sup>2</sup> )
					[Pi 71 040 DN]	[Pi 72 040 DN]	[Pi 73 040 DN]	[Pi 74 040 DN]	[Pi 75 040 DN]
					794.065.3	796.010.7	793.082.9	826.982.1	826.090.3
[Pi 21 040 DN]	[Pi 22 040 DN]	[Pi 23 040 DN]	[Pi 24 040 DN]	[Pi 25 040 DN]					
822.752.2	796.084.2	792.562.1	826.110.9	826.111.7					

\* Further elements available upon request

## 8. Specifications

Design:	line mounting filter
Operating pressure:	200 bar*
Static test pressure:	260 bar*
Temperature range:	-10 °C to +120 °C (other temperature ranges on request)
Bypass opening pressure:	$\Delta p$ 7 bar $\pm$ 10 %
Filter head material:	GGG
Filter bowl material:	St
Material of seals:	NBR / PTFE / Cu
Activating pressure of visual / electrical differential pressure indicator:	$\Delta p$ 5 bar $\pm$ 10 %
Electrical data of contamination indicator:	
Maximum voltage:	230 V $\sim$ / =
Maximum current on contact:	2,5 A
Maximum contact load:	60 VA / 40 W
Inrush current:	70 VA
Type of protection:	IP 65 when inserted and secured
Contact:	bistable
Cable connection:	PG 11 $\varnothing$ 6-10

The electrical indicator function can be changed from the Normally Open position to the Normally Closed position or visa versa by inverting the electrical section.

With the inrush current of 70 VA the indicator can trigger small contactors or contactor relays.

Inductivity in the direct current may require the use of a signal eraser.

For further information and executions please see our leaflet "contamination indicators".

Filters compatible with standard mineral oils.

Please contact us in case of using other media.

\* Types Pi 30 004 – Pi 30 010 have an operating pressure of 315 bar/test pressure 410 bar.

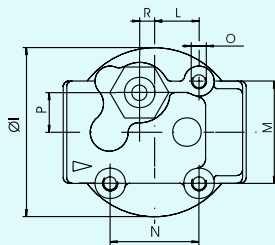

NG 40 - 100

Pos 1 - Visual contamination indicator

Pos 2 - El. upper section connector according DIN 43650  
Execution: Pis 3092, 3105, 3115

Pos 3 - El. upper section connector according DIN 43651  
Execution: Pis 3102, 3122, 3110, 3132

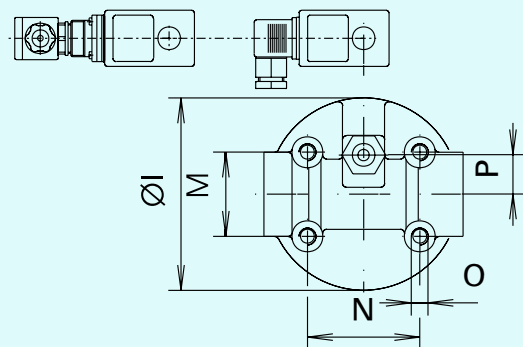
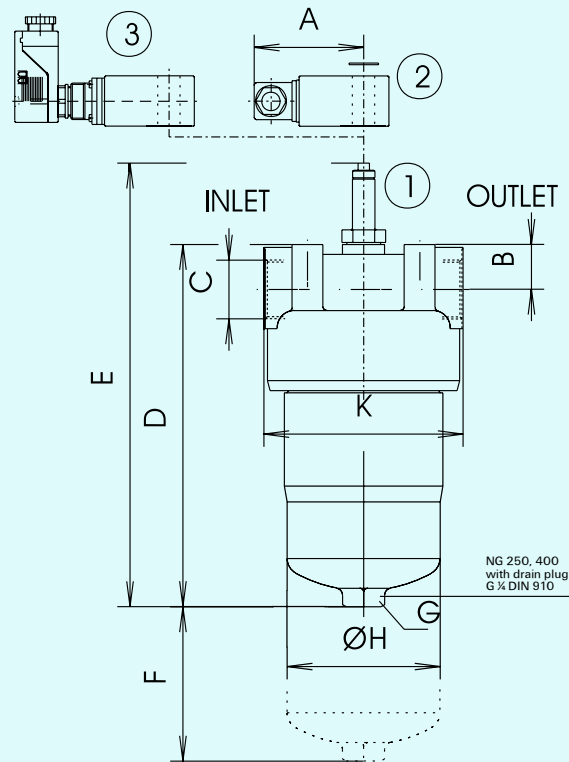

NG 160 - 400

## 9. Dimensions

All dimensions (except "C") in mm

Dimension Type	A	B	C	D	E	F	G (SW)	H	I	K	L	M	N	O	P	R	Weight [kg]
Pi 30 004	78	31	G ½	194	252	80	27	66	90	92	23,5	54	47	M8x16	21	8	4,2
Pi 30 006	78	31	G ¾	254	312	80	27	66	90	92	23,5	54	47	M8x16	21	8	4,9
Pi 30 010	78	31	G 1	344	402	80	27	66	90	92	23,5	54	47	M8x16	21	8	5,8
Pi 30 016	78	32	G 1 ¼	268	326	110	30	109	137	142	-	60	80	M 12x16	28	-	10,0
Pi 30 025	78	32	G 1 ¼	368	426	110	30	109	137	142	-	60	80	M 12x16	28	-	12,0
Pi 30 040	78	32	G 1 ¼	518	576	110	30	109	137	142	-	60	80	M 12x16	28	-	15,6

## 10. Installation, operating and maintenance instructions

### 10.1 Filter installation

When installing the filter make sure that sufficient space is available to remove filter element and filter bowl. Preferable the filter should be installed with the filter bowl pointing downwards. The contamination indicator must be visible.

### 10.2 Connecting the electrical contamination indicator

The electrical indicator is connected via a 2-pole appliance plug according DIN 43650 with poles marked 1 and 2. The electrical section can be inverted to change from Normally Open position to Normally Closed position or visa versa.

### 10.3 When must the filter element be replaced?

- Filters equipped with visual and electrical contamination indicator:  
During cold starts, the indicator may give a warning signal. Depress the red button of the visual indicator once again only after operating temperature has been reached. If the red button immediately pops out again and/or the electrical signal has not switched off after reaching operating temperature, the filter element must be replaced after the end of the shift.
- Filters without contamination indicator:  
The filter element should be replaced after the trial run or flushing of the system. Afterwards follow instructions of the manufacturer.
- Please always ensure that you have original MAHLE-replacement elements in stock: disposable elements (Sm-x) cannot be cleaned.

### 10.4 Element replacement

- Stop system and relieve filter from pressure.
- Unscrew the filter bowl by turning counter-clockwise. Clean the bowl using a suitable cleaning solvent.
- Remove filter element with a side-to-side motion.
- Check O-ring and back-up ring on the filter bowl for damage. Replace, if necessary.
- Make sure that the part number on the spare element corresponds with the part number of the filter label. Open the plastic bag and push element over the spigot in the filter head. Now remove plastic bag.
- Complete installation by screwing on the bowl, turning clockwise until it comes to a full stop. Back off the bowl  $\frac{1}{8}$  to  $\frac{1}{2}$  turn.

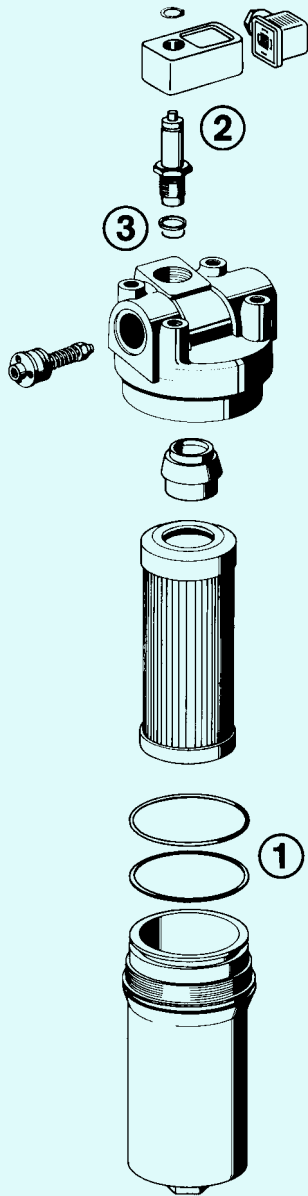

## 11. Spare parts list

Pos.	part number / housing		
	Pi 30 004-Pi 30 010		Pi 30 016-Pi 30 040
①	Seal kit		Seal kit
	NBR	838.374.7	NBR 838.377.0
	FPM	838.375.4	FPM 838.378.8
	EPDM	838.376.2	EPDM 838.379.6
②	Contamination indicator		electrical upper section only
	visual	electrical	
	766.991.4	766.986.4	753.655.0
	Pis 3093/5 bar	Pis 3092/5 bar	
③	Seal kit for contamination indicator		
	NBR	776.027.5	
	FPM	776.028.3	
	EPDM	776.029.1	

Subject to technical alteration without prior notice.

# MAHLE

MAHLE Filtersysteme GmbH

Bereich Industriefilter · Schleifbachweg 45 · D-74613 Öhringen · Postfach 13 09 · D-74603 Öhringen  
 Telefon (0 79 41) 67-0 · Telefax (0 79 41) 67-429 · Internet: <http://www.mahle.com> · E-mail: [ub2.industrie@mahle.com](mailto:ub2.industrie@mahle.com)