

Vertical pressure leaf filter MVDCD with U-stamp

1. Introduction

The amafilter vertical pressure leaf filter is a pressure filter with a large specific filtration area due to the shape of the filter elements. We have been building these filters for more than 60 years. The amafilter MVDCD range incorporates several product improvements making the design state of the art. More than 10000 vertical and horizontal pressure leaf filters have been sold world-wide for various applications so far.

The double sided filter leaves are made from stainless steel. The rigid filter leaves have five layers of stainless steel wire screen. The top layer of screen depends on the application. The filter leaves are individually mounted on the central manifold, which allows the removal of any or all of the filter leaves easily and quickly.

The filter cake can be dried with compressed air, inert gas or steam. The cake is discharged by a pneumatic vibrator, through a large butterfly valve.

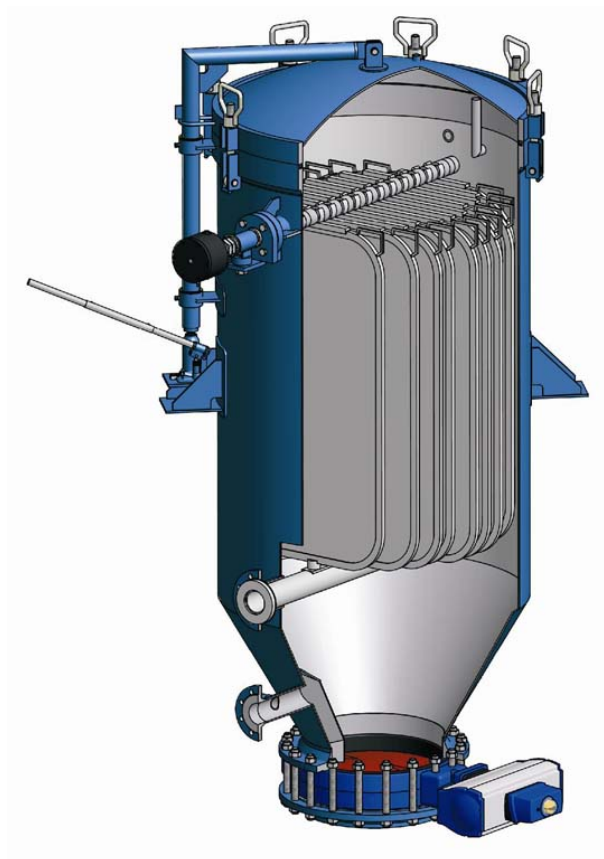

2. Pressure leaf system advantages

The pressure leaf filter is an enclosed filtration system and can be fully automated. This filter produces a high filtrate clarity after the clarification run and is also suitable for all kinds of filter aids. The regeneration time between the filtration cycles is short. The vertical filters require only a small footprint and are standard equipped with a cover lift assembly. The design of the pressure leaf filter keeps maintenance to a minimum.

These advantages result in an economical filtration solution.

3. Standard design data

Material tank	: carbon steel (stainless steel optional)
Material filter elements	: stainless steel
Design pressure	: -1/6 bar(g) (-14.5/87 psig)
Design temperature	: 0/150 °C (32/302 150 °F)
Max. allowable pressure drop	: 4.5 bar (65 psi)
Design	: ASME VII div. 1
Approval	: U-stamp

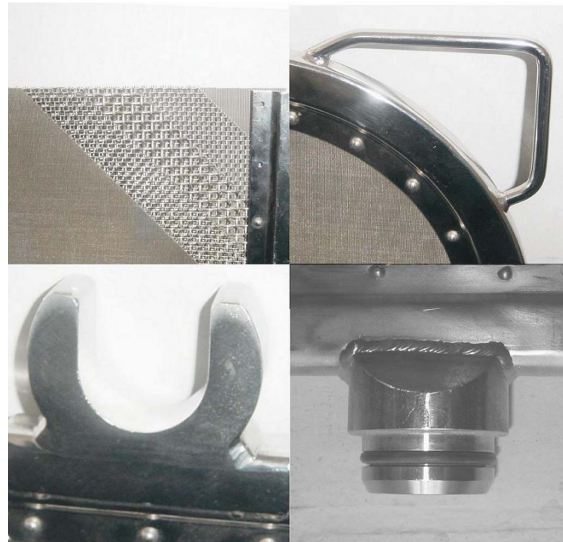

Versis model	508	610	711	780	900	1100	1225	1380	1500 (1500)	1500 (1650)	1650	1850
Tank diameter [mm]	460	610	711	780	900	1100	1225	1380	1500	1600	1800	2000
Element height [mm]	550	550	920	920	1250	1250	1250	1350	1500	1650	1800	1800
Feed / Drain [inch]	2	2	2	2	2	3	3	4	4	4	5	5
Filtrate outlet [inch]	3	3	3	3	3	4	4	5	5	5	5	5
Vent [inch]	1	1	1	1	1	1	1	2	2	2	2	2
Cake discharge [inch]	8	8	10	12	14	20	20	24	24	24	24	24

4. Specifications

MVDCD Model	Filter Area [m ²]	Cake volume [dm ³]	Filter leaves [-]	Filter volume [dm ³]	Leaf spacing [mm]	Floor space [mm x mm]	Height* [mm]	Weight (empty) [kg]
508/550/1.6/5	1.65	35	5	210	70	1220 x 1100	2110	350
610/550/2.2/5	2.2	50	5	320	70	1320 x 1300	2210	400
711/920/3/3	3	70	3	600	70	1340 x 1540	3020	550
711/920/4.8/5	5	105	5					
711/920/6.2/7	7	135	7					
780/920/5/5	5	110	5	800	70	1750 x 1090	3090	650
780/920/7/7	7	155	7					
780/920/8/9	9	175	9					
900/920/8/7	8	175	7	1000	70	1190 x 1230	3190	800
900/920/10/9	10	220	9					
900/920/12.5/11	12.5	275	11					
1100/1250/15/9	15	330	9	2000	70	2370 x 1680	4000	1100
1100/1250/17.5/9	17.5	385	9					
1100/1250/20/11	20	440	11					
1225/1250/23.5/11	23.5	520	11	2500	75	2210 x 2650	4100	1725
1225/1250/25/11	25	550	11					
1225/1250/27/13	27	590	13					
1225/1250/30/15	30	660	15					
1380/1250/30.5/11	30.5	670	11	3600	75	2900 x 2110	4500	1980
1380/1350/35/13	35	770	13					
1380/1350/38.5/15	38.5	850	15					
1500/1500/42/13	42	920	13	4500	75	3110 x 230	4880	2300
1500/1500/46	46	1010	15					
1500/1500/50/17	50	1100	17					
1500/1650/55/15	55	1210	15	4900	75	3110 x 2350	5180	2500
1500/1650/60/17	60	1320	17					
1650/1800/70/16	70	1540	16	6300	75	3770 x 2640	5650	3200
1650/1800/78/18	78	1720	18					
1850/1800/85/16	85	1870	16	8200	75	3440 x 3890	3000	4400
1850/1800/100/20	100	2200	20					

*incl. lifting height for elements

Other models upon request

Notes: *Dimensions are for reference only.
Subject to technical alteration without prior notice.*

MAHLE

Industrial Filtration

MAHLE Industrial Filtration (Benelux) B.V.

P.O.Box 396 1800 AJ

Alkmaar - The Netherlands

Phone +31 (0) 72 5273400

Fax +31 (0) 72 5125207

mahle.amafilter@mahle.com

www.mahle-industrialfiltration.com

10/2009