

**Press conference on the business development of  
the MAHLE Group for the 2016 business year**

**April 26, 2017**

Press conference 2017

Strategic decisions characterize the 2016 business year

**MAHLE**

*Driven by performance*



## Business development of the MAHLE Group in 2016

### Sales development [in million EUR]

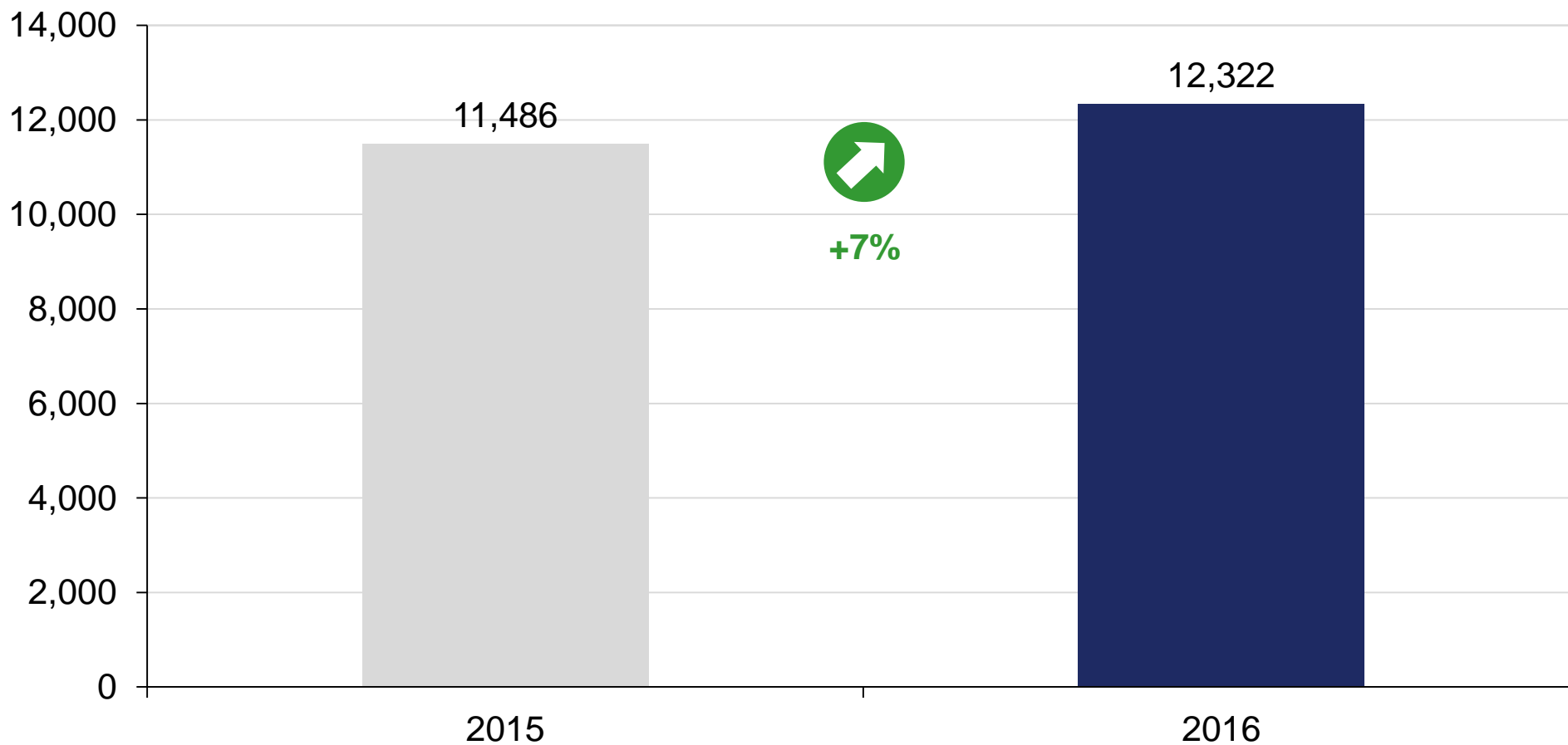

Further strong growth of 7.3% in 2016

# Business development of the MAHLE Group in 2016

## Investments in research and development [in million EUR]

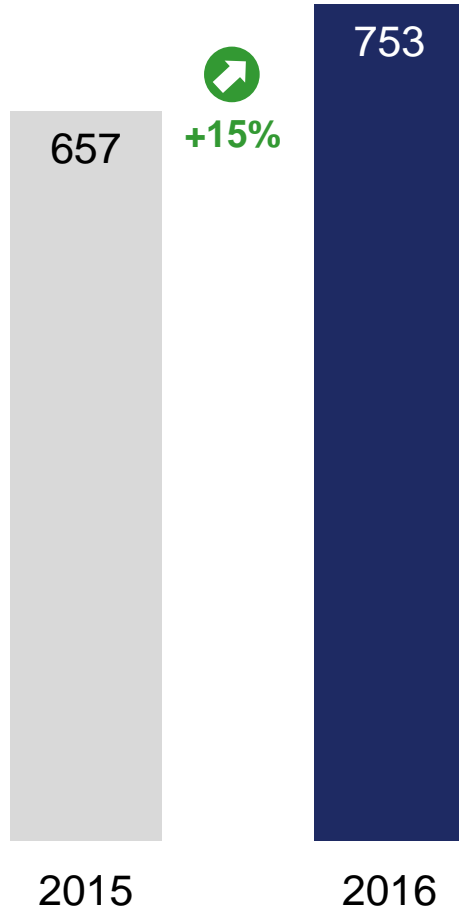

Innovative strength bolstered in new product areas

Press conference 2017

## Sales development of the new Mechatronics business segment [in million EUR]

**MAHLE**

*Driven by performance*

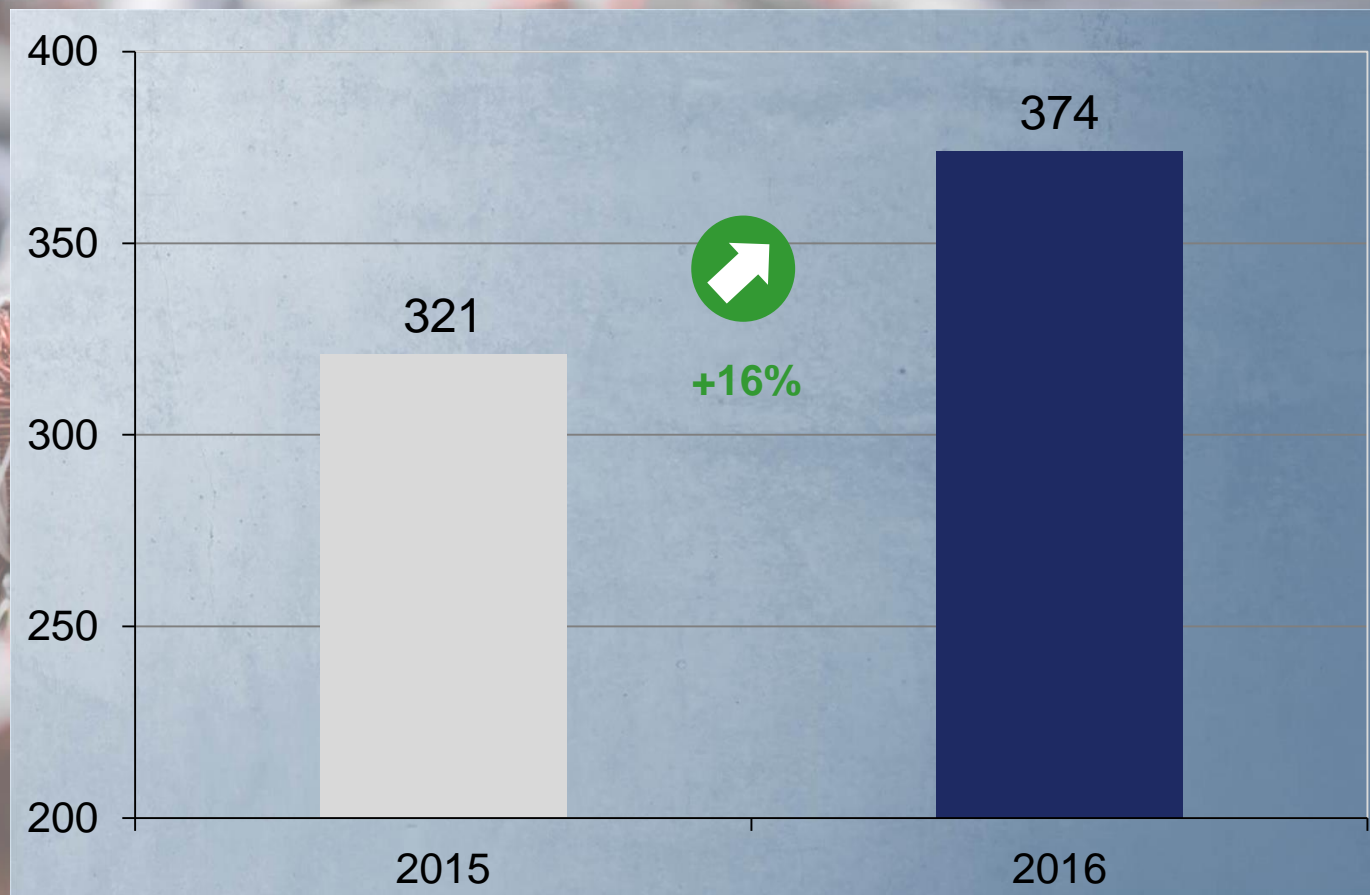

Strong growth in the strategic Mechatronics business segment

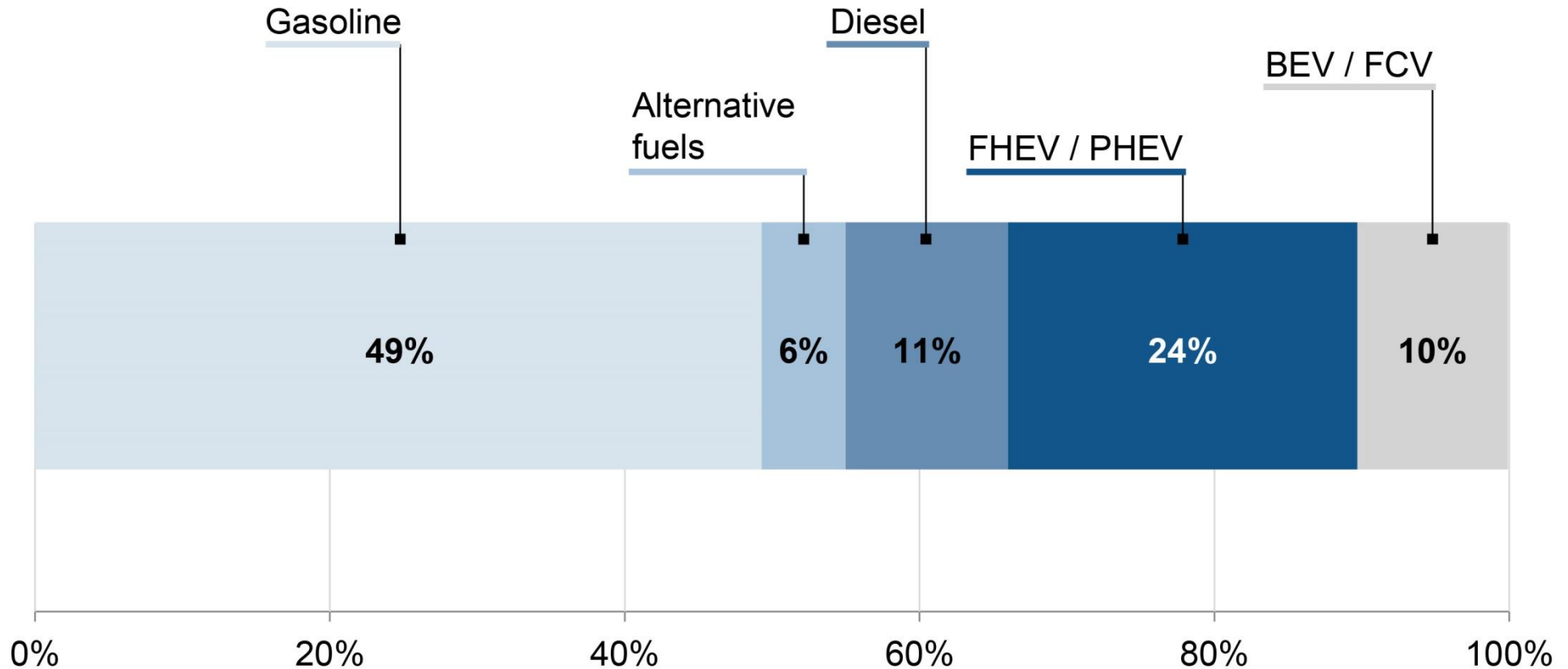

2030 forecast: production of around 108 million passenger cars and light commercial vehicles—approx. 97 million will run with combustion engines

# Sales: impact of euro exchange rate effect and first consolidation [in million EUR]

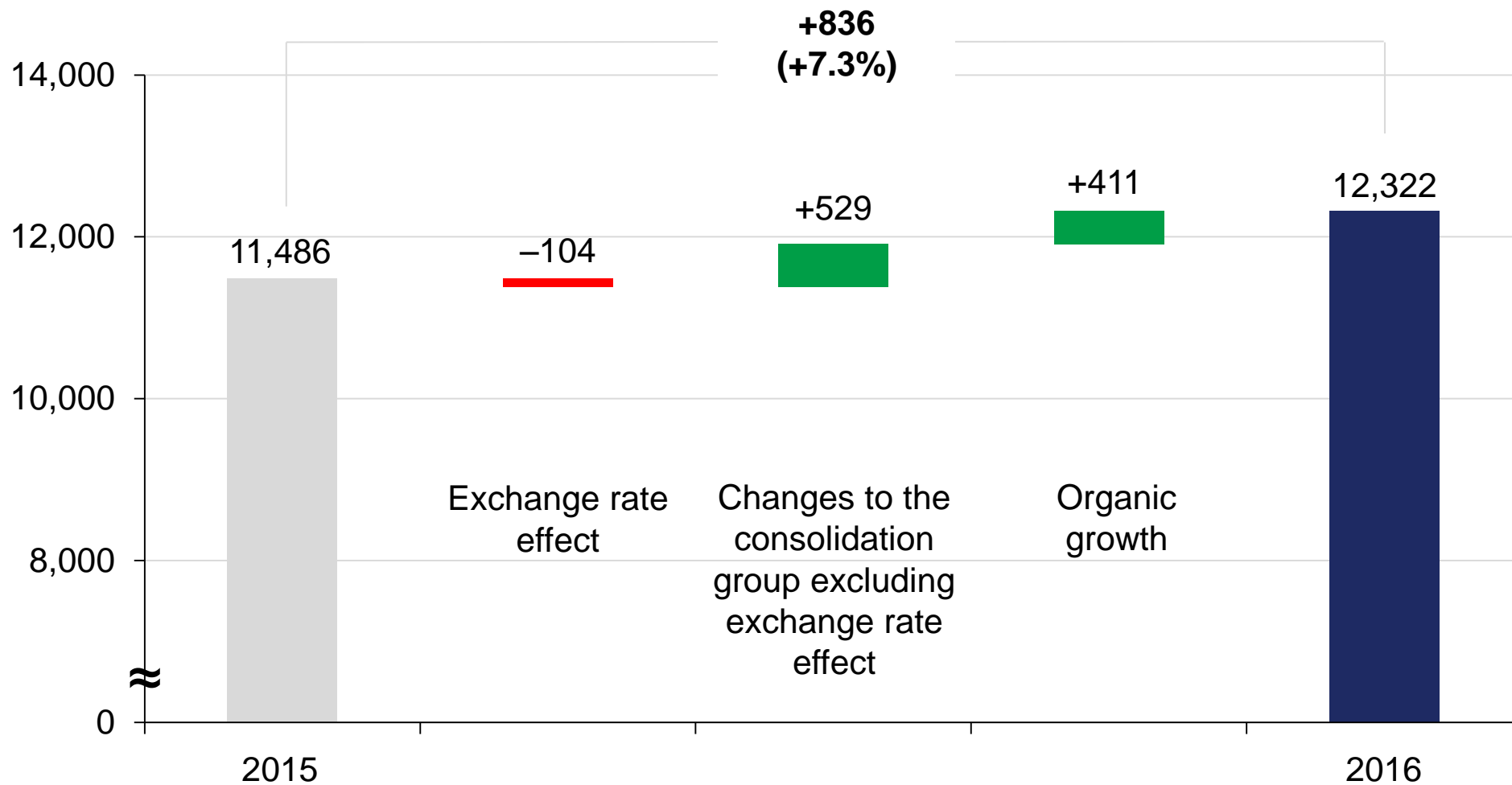

# 2016 sales by business segment [in million EUR]



*Driven by performance*

Group sales 2016: EUR 12,322 million

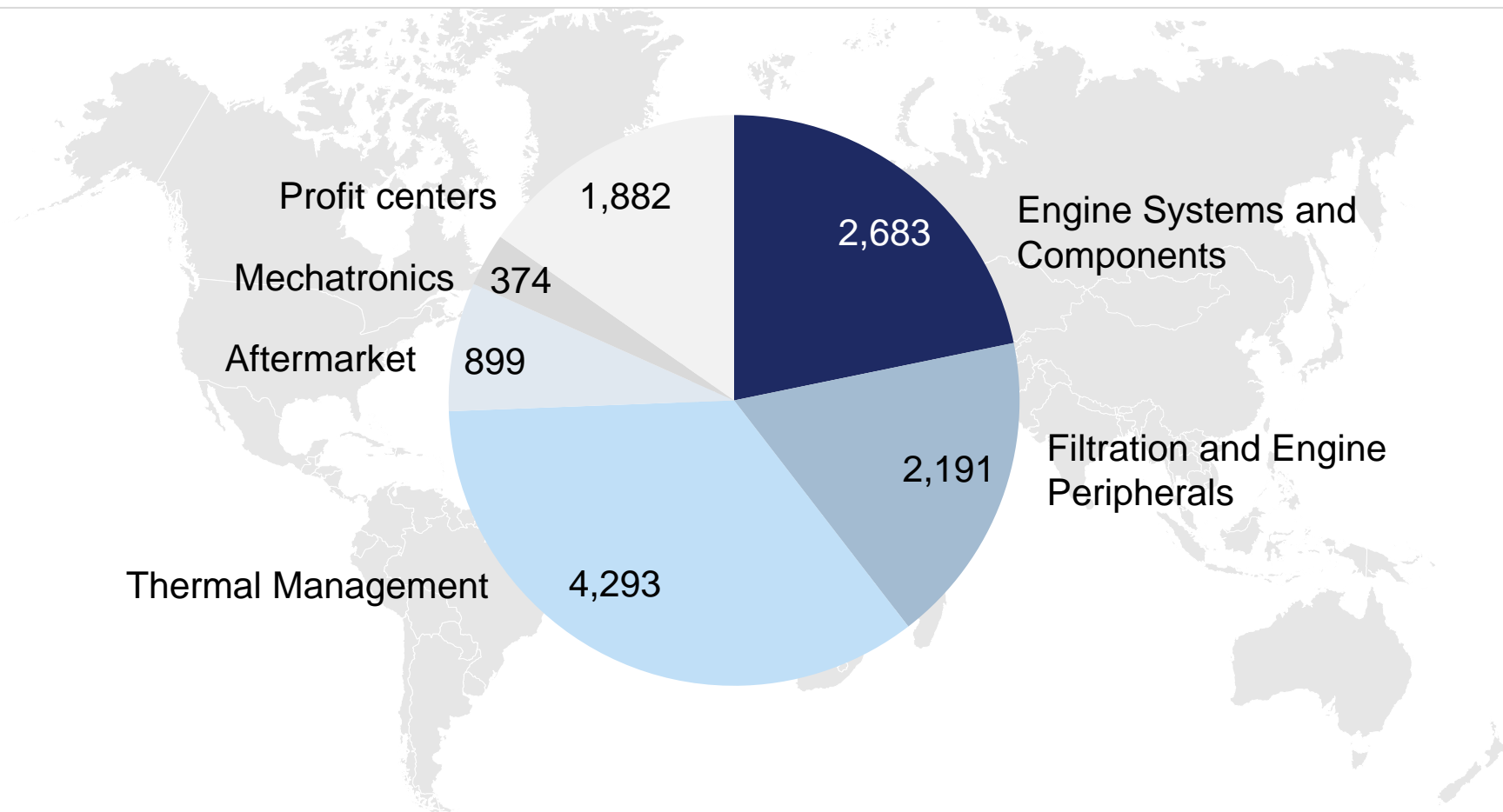



Press conference 2017  
2016 sales by region  
[in %]



*Driven by performance*

Group sales 2016: EUR 12,322 million

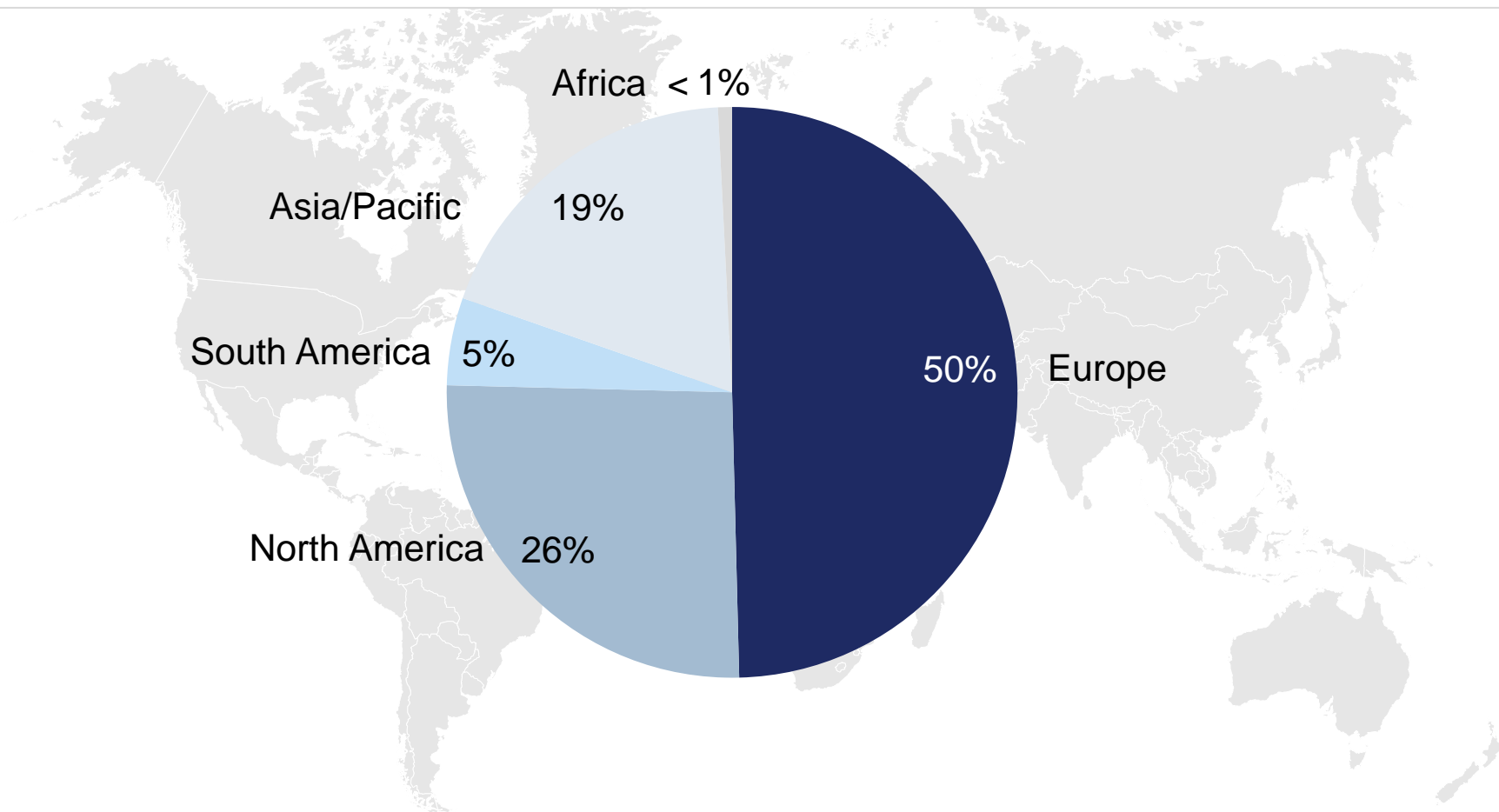

	<b>2016</b> in million EUR	<b>in %</b> of sales	<b>2015</b> in million EUR
EBITDA	1,079	8.8	1,093
EBIT	473	3.8	511
Result after taxes	96	0.8	153
Consolidated net income	63	0.5	122
Equity ratio		33.9	34.0

# Business development of the MAHLE Group in 2016

## Capital expenditure on tangible fixed assets (excluding first consolidation)

*Driven by performance*

[in million EUR]

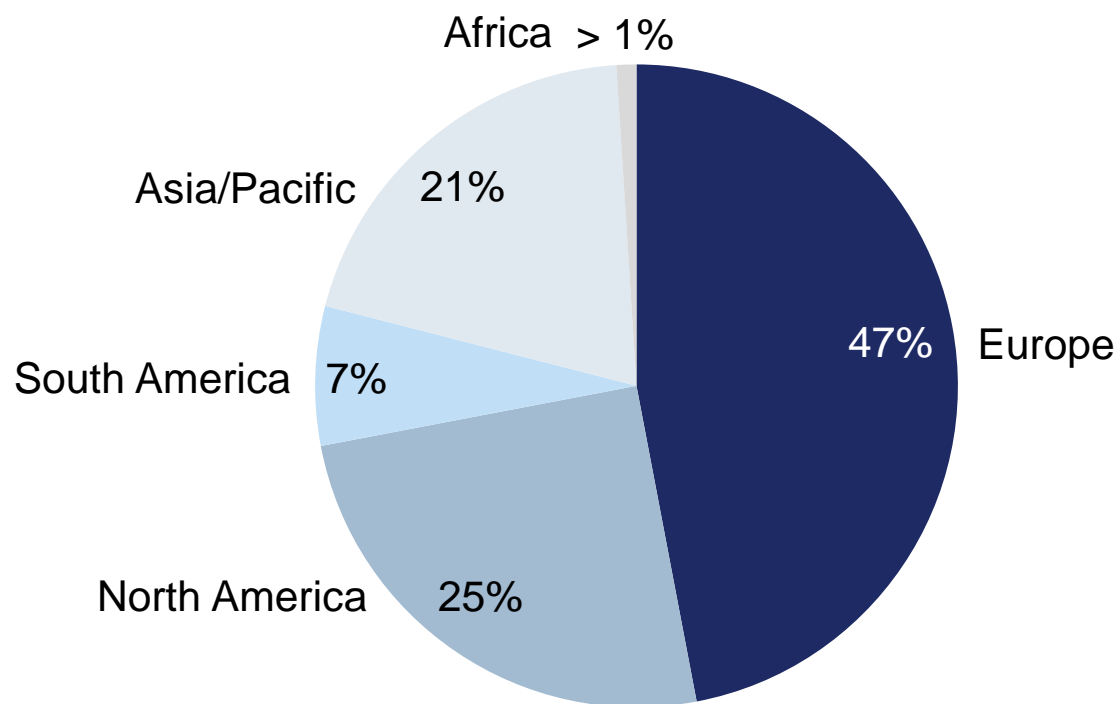
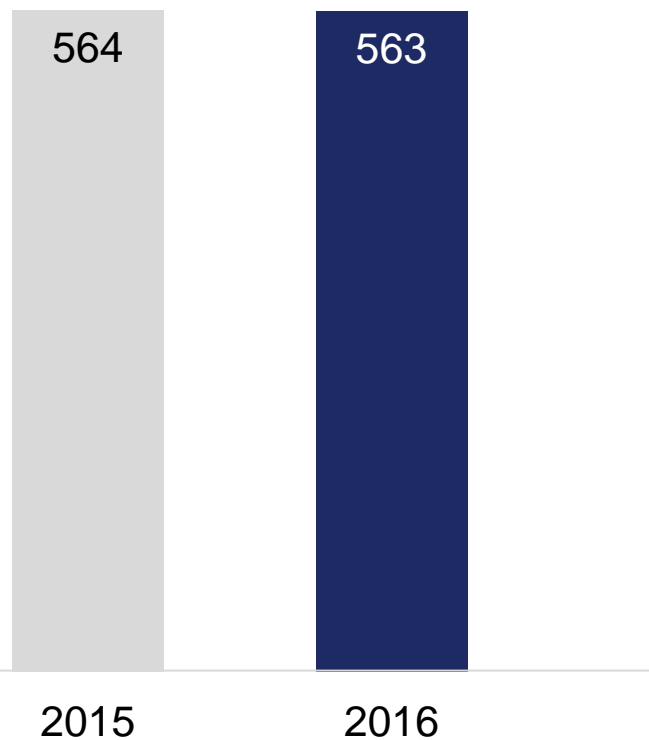



With the MAHLE portfolio alone, a further reduction of around ten percent in CO<sub>2</sub> emissions can be achieved for the combustion engine.

MAHLE technologies for significant CO<sub>2</sub> reductions

The monovalent CNG engine from MAHLE reduces CO<sub>2</sub> emissions by 25% (WLTC).



Alternative fuels are the fastest route to reducing CO<sub>2</sub>

**Fast charging without damaging the batteries through MAHLE battery cooling systems**



**MAHLE solutions improve the competitiveness of electric vehicles**

Integrated and intelligent thermal management is a prerequisite for establishing e-mobility.

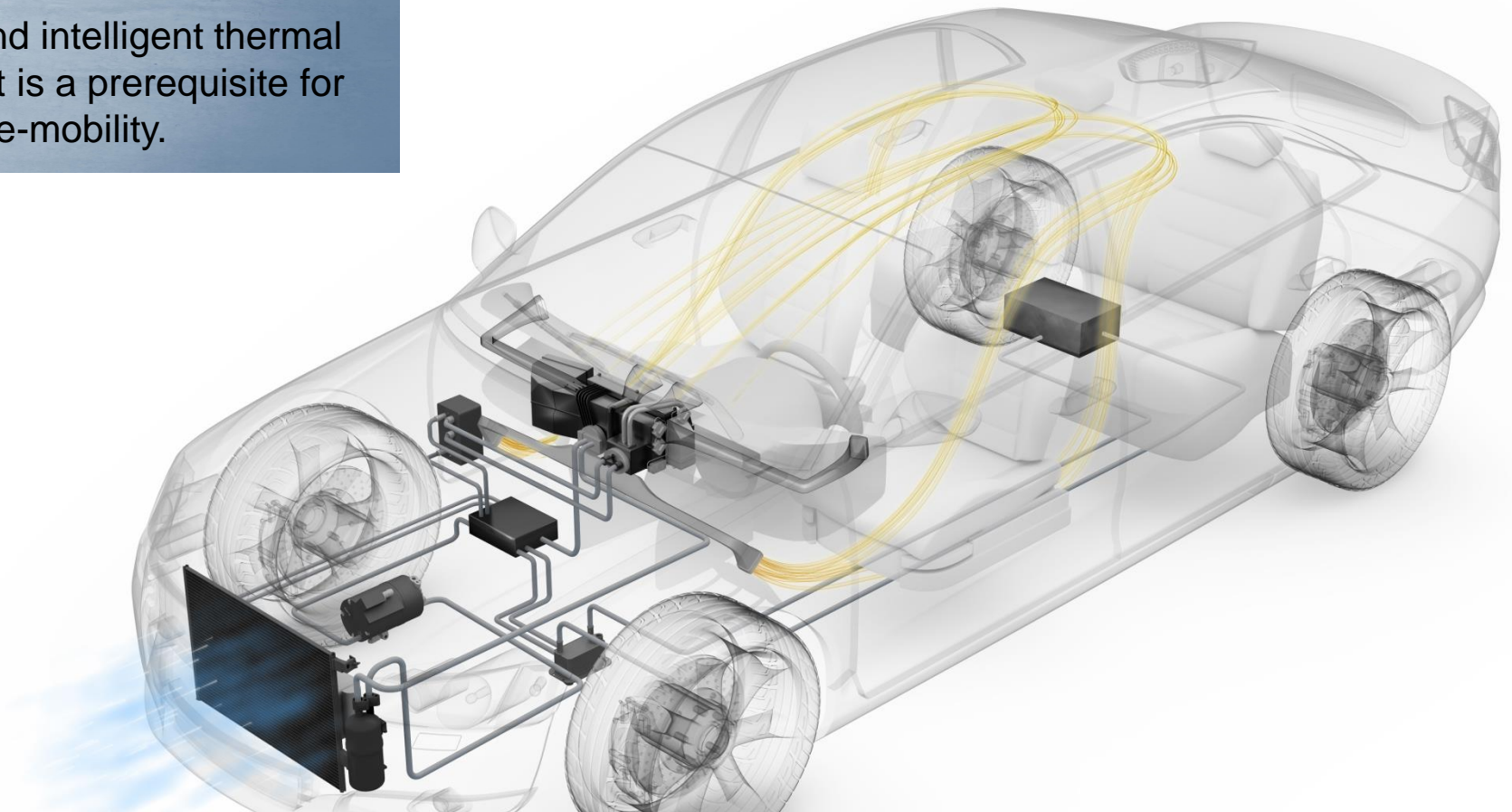

Thermal management is an enabler for e-mobility

Highly efficient drive systems, power electronics, and electric auxiliary components from MAHLE are experiencing global demand.



Electric drive solutions from MAHLE are in demand worldwide



Strategically, we have taken a major step toward reaching our goal of having the holistic systems competence for electrification and e-mobility within our company.

MAHLE expands its holistic systems competence for e-mobility

With R744 air conditioning systems, we now offer an environmentally-friendly response to the European Union's refrigerant guidelines.

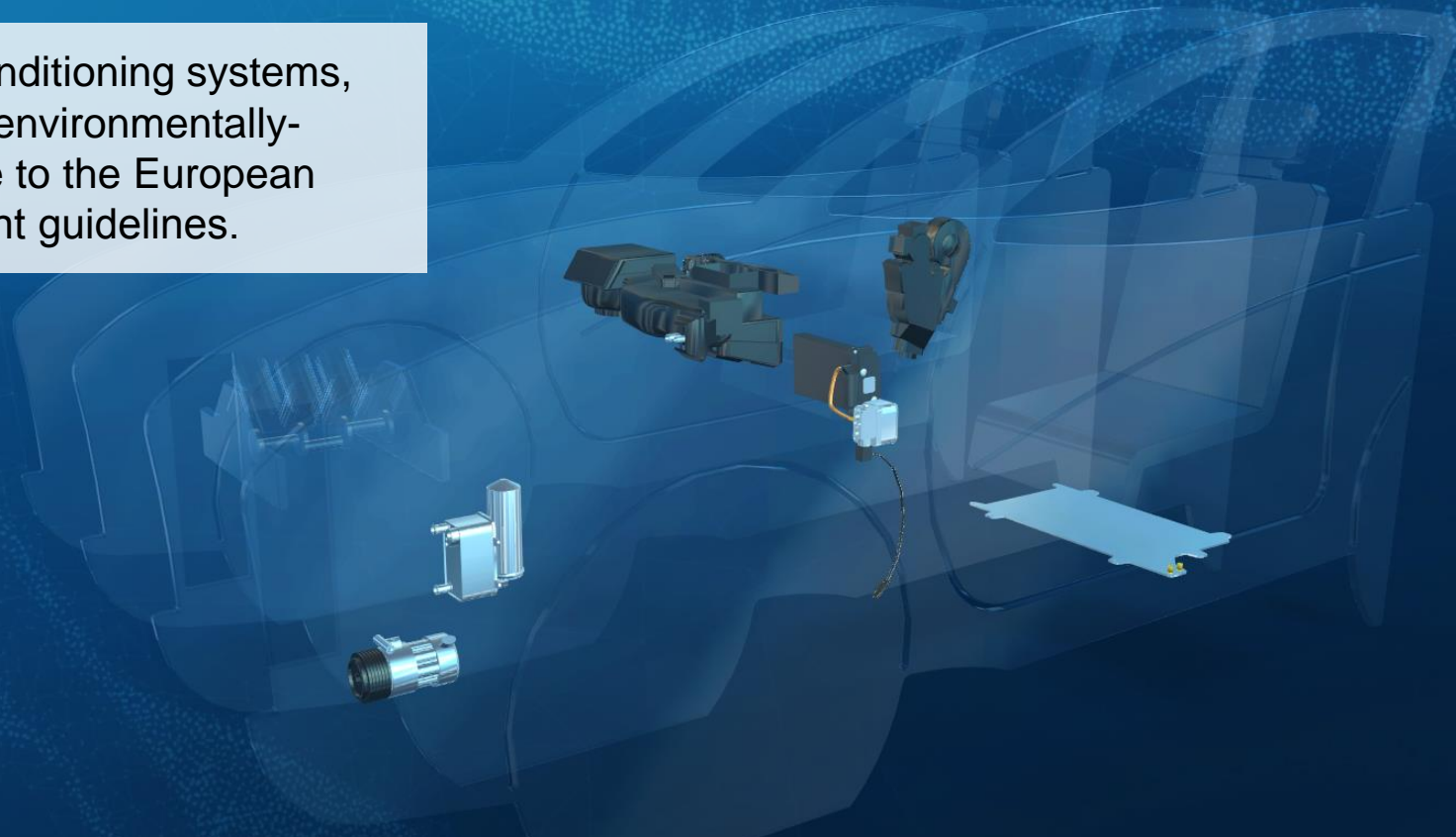

MAHLE solutions for the environment—even beyond the powertrain technology



MAHLE innovations for combustion engine and electric vehicles